



Direct Air Capture and Ocean Storage Methodology for CO₂ Removal

Edition 2025 v. 0.95

Puro Standard
January, 2025

Draft for public consultation

Document name	Direct Air Capture and Ocean Storage
Document version	Edition 2025 v. 0.95 (draft)
Date of release	January 29 th , 2025
Applicable methodologies	Direct Air Capture and Ocean Storage, Edition 2025 (pending approval)

DRAFT FOR PUBLIC CONSULTATION

Direct Air Capture and Ocean Storage
Methodology for CO₂ Removal

Edition 2025 v. 0.95

Puro Standard
January, 2025

Contents

Glossary of terms.....	4
Acronyms	5
Chemical species.....	6
Note to the reader	7
Document history	8
1 Introduction.....	9
1.1 Overview	9
1.2 Scope	10
1.3 Operational principles.....	10
1.4 Mechanism of carbon sequestration.....	12
2 Point of creation of the CO₂ Removal Certificate (CORC).....	16
2.1 CO ₂ Removal Supplier.....	16
2.2 Production Facility and Crediting Period.....	16
2.3 Point of creation.....	16
3 Eligibility requirements	17
3.1 Overview	17
3.2 General eligibility	17
3.3 CO ₂ Removal Supplier.....	18
3.4 End of Use or Disposal of Carbonate Minerals.....	19
3.5 CO ₂ removal Baseline demonstration.....	21
3.6 Additionality.....	22
3.7 Prevention of double counting.....	22
3.8 Environmental and social safeguards	23
3.9 Requirements for positive sustainable development goals impacts.....	27
4 Quantification of CO₂ Removal Certificates (CORCs).....	29
4.1 Overview	29
4.2 Overall equation	29

4.3	Carbon dioxide stored (C_{stored})	30
4.4	Project emissions (E_{project})	34
4.5	Ecological, market, and activity-shifting indirect emissions (E_{indirect})	35
4.6	Losses (C_{loss}).....	36
4.7	Baseline removal ($C_{\text{baseline removal}}$)	38
4.8	Summary of parameters	40
5	Determination of project emissions (E_{project})	43
5.1	General life cycle assessment requirements	43
5.2	Methodology-specific life cycle assessment	45
5.3	Emissions allocation to co-products	56
5.4	Cut-off criteria.....	57
6	Determination of indirect emissions (leakage).....	59
6.1	Overview	59
6.2	Identification and characterization of indirect emission sources	59
6.3	Mitigation of indirect emission sources	60
6.4	Quantification of non-mitigated indirect emissions.....	63
7	Monitoring and reporting	65
7.1	Overview	65
7.2	General monitoring requirements	66
7.3	Process boundaries for monitoring.....	69
7.4	Monitoring Parameters and Descriptions.....	71
7.5	Monitoring of environmental and social impacts.....	77
7.6	Data Management	78
7.7	Uncertainty assessment.....	81
7.8	Performance reporting.....	85
8	Risk assessment and management.....	87
8.1	Overview	87
8.2	Permanence and risk of reversal	90
8.3	Requirements for risk assessment and management.....	91
	References	93

Glossary of terms

REMARK: This glossary provides only the most important definitions for the current methodology. Please note that further definitions are listed in the Puro Standard General Rules.

Anode – The electrode of a polarized electrical device at which oxidation occurs. In an electrochemical cell, this is the positively charged electrode.

Alkaline Rock – Rock additive that neutralizes the low pH stream from the anode. Throughout this methodology, various other terms such as such as rock, ground rock, alkaline feedstock, crushed rock, and rock dust are also utilized to refer to alkaline rock.

Balance of Plant – The various supporting components and auxiliary systems of the electrochemical processing facility (aside from the electrolyzer itself) such as the catholyte and anolyte processing equipment.

Book and Claim – Book-and-claim accounting of low-carbon intensity electricity refers to a practice where a reporting entity uses indirect accounting to claim environmental attributes produced remotely.

Cathode – The electrode of a polarized electrical device at which reduction occurs. In an electrochemical cell, this is the negatively charged electrode.

Electrolyzer – A system comprising anodes and cathodes that uses an electrical current to split water molecules into hydrogen and oxygen, and/or acid and base.

Incrementality – The requirement for additionality of the renewable energy product under Section 45V of the Inflation Reduction Act of 2022 (see also *Section 45V*).

Indirect emissions – see *Leakage*.

Products – Products from the electrochemical processing system, including solid calcium carbonate (CaCO_3), bicarbonate ions (HCO_3^-) and dissolved inorganic carbon (DIC), hydrogen (H_2), oxygen (O_2), acid (H^+) and base (OH^-).

Section 45V – United States federal regulations regarding credits for production of clean hydrogen. More precisely, regulations amending the United States Income Tax Regulations under Title 26 of the United States Code of Federal Regulations, Section 45V, as enacted by the Inflation Reduction Act of 2022.

Leakage – An indirect effect associated with a CO_2 Removal activity and dependent on the selected Baseline, that may lead to an increase or decrease in greenhouse gas emissions or removals, outside of the system boundaries of the activity, if not avoided or mitigated. It is also called indirect emissions in the net CO_2 Removal quantification.

Acronyms

°C – Degrees Celsius

BOL – Bill of lading

CDR – Carbon dioxide removal

CI – Carbon intensity

CO_{2e} – Carbon dioxide equivalent

CWA – Clean Water Act

DACOS – Direct air capture and ocean storage

DPA – Direct purchase agreement

EIA – Environmental impact assessment

EPMA – Environmental protection and management act

GAC – Granular activated carbon

GHG – Greenhouse gas

Gt – Gigatonne

GOO – Guarantee of origin

ISO – International Organization of Standardization

LCA – Life-cycle analysis

MRV – Monitoring, reporting, and verification

MSFD – Marine strategy framework directive

MWh – Megawatt-hour

OEM – Original equipment manufacturer

OER – Oxygen-evolution reaction

OSHA – Occupational safety and health administration

ppm – Parts per million

QA – Quality assurance

QC – Quality control

REC – Renewable energy certificate

SSR – Source, sinks, reservoirs

TGA – Thermogravimetric analysis

TSS – Total suspended solids

USEPA – United States Environmental Protection Agency

XRD – X-ray diffraction

Chemical species

CO₂ – Carbon dioxide

CaCO₃ – Calcium carbonate

Cl₂ – Chlorine gas

CO₃²⁻ – Carbonate ion

DIC – Dissolved inorganic carbon, including carbonate anion (CO₃²⁻), bicarbonate anion (HCO₃⁻), carbonic acid (H₂CO₃), and dissolved CO₂ (CO₂(aq))

H₂ – Hydrogen gas

HCO₃⁻ – Bicarbonate ion

H₂CO₃ – Carbonic acid

MgCO₃ – Magnesium carbonate

MgCO₃·3H₂O – Nesquehonite

MgCO₃·5H₂O – Lansfordite

Mg₅(CO₃)₄(OH)₂·4H₂O – Hydromagnesite

Mg₅(CO₃)₄(OH)₂·5H₂O – Dypingite

Mg(OH)₂ – Magnesium hydroxide

O₂ – Oxygen gas

OH⁻ – Hydroxide ion

Note to the reader

This methodology has been completed in collaboration with Equatic, as an external methodology to be adopted into the Puro Standard. The Puro.earth team would like to thank the Equatic team and their contributors for the development of this methodology.

REMARK: This methodology provides general information as well as actual requirements which must be met by all projects seeking certification under the Puro Standard. Across the entire methodology, the requirements correspond to numbered rules with formatting conforming to the below example.

0.0.1 This is an example of a numbered rule. The requirements set within numbered rules must be followed by all projects seeking certification under the Puro Standard.

Please note that in addition to the requirements of this methodology document, all projects seeking certification under the Puro Standard must also comply with the Puro Standard General Rules and other Standard Requirements, as well as any applicable local laws, regulations, and other binding obligations.

For Puro Standard documents, see the [Puro Standard documents library](#).

Document history

Edition 2025 v. 1 ([date], 2025) — Initial release.

1 Introduction

1.1 Overview

This methodology sets the requirements for eligibility and quantification of the net CO₂ removal, and storage for over one thousand (1,000) years,¹ via the Direct Air Capture and Ocean Storage (DACOS) of eligible CO₂.

In this methodology, DACOS refers to the overall process of a CO₂ removal method where, first, renewable energy is used to split seawater into different streams via electrolysis and, second, air is contacted with one of those streams to remove CO₂ as solid carbonates and aqueous bicarbonates (La Plante et al., 2021, 2023). The CO₂ enriched seawater and solid minerals are stable over geologic time periods (Renforth & Henderson, 2017) and there is thus no effective risk of reversal (Cross et al., 2023). The overall process is schematically depicted in [Figure 1.1](#).

The DACOS process is performed with seawater in a closed system and requires a facility with access to seawater and an abundant supply of low carbon-intensity power, alkaline rock, and atmospheric CO₂. The composition of the seawater is changed between the input and output through an increase in dissolved bicarbonate and carbonate ion concentrations and solid carbonates. The main process *inputs* are:

- seawater,
- alkaline rock,
- atmospheric CO₂, and
- electricity,

while the main *outputs* are:

- seawater enriched in carbonate (CO₃²⁻) and bicarbonate (HCO₃⁻) ions,
- carbonate solids (e.g. calcium carbonate, CaCO₃),
- hydrogen (H₂), and
- oxygen (O₂).

The total net amount of CO₂ removal is calculated by converting the carbon removed to CO₂ equivalents and subtracting from this gross amount the process emissions generated by the project activities, as well as other potential losses (see [section 4.1](#)). The remaining net amount of carbon dioxide removal is then credited as CO₂ Removal Certificates (CORCs).

¹ Note that the storage period of 1000 years refers to the period of time for which the CO₂ removal is certified and is not indicative of a scientific upper bound of CO₂ storage durability. In fact, on a global scale, the residence time for alkalinity in the ocean is on the order of tens of thousands of years (Cross et al., 2023) and forms, for all practical purposes, a permanent sink for anthropogenic CO₂ (Renforth & Henderson, 2017).

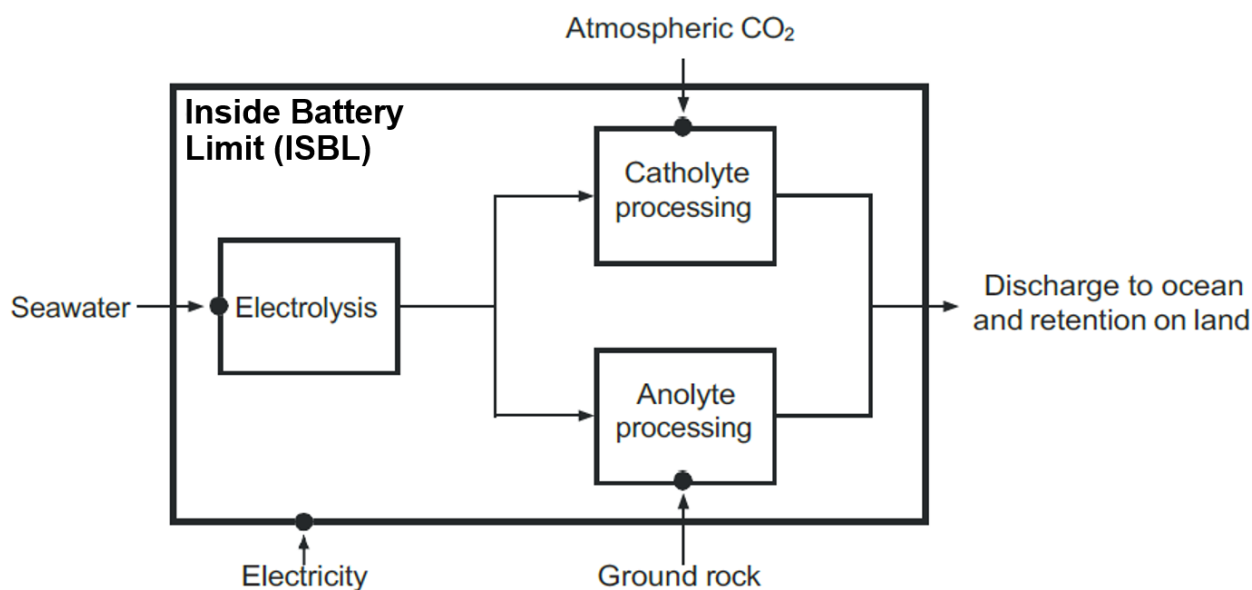

Figure 1.1 A schematic overview of the DACOS process.

1.2 Scope

In broad terms, the scope of this methodology includes the following fundamental components:

- the sourcing of raw materials (alkaline rock),
- the electrochemical processing of seawater to capture (absorb) and sequester atmospheric CO₂ (i.e. the intake of seawater, the closed system reaction, and ultimately discharge of the processed water), and
- the disposal of solid carbonate minerals.

The scope of this methodology *does not include* any processes where the chemical reactions governing the dissolution and durable storage of CO₂ have not reached an equilibrium within a closed system. Examples of such processes include Ocean Alkalinity Enhancement (OAE)² and Direct Ocean Capture (DOC)³ (Cross et al., 2023).

1.3 Operational principles

In simple terms, the DACOS process utilizes an electrolyzer (i.e. a device which uses electricity to split water into hydrogen and oxygen, and acid and base) to produce a stream of acidified seawater (decrease in pH), and alkaline seawater (increase in pH). The acidified seawater is treated with

² OAE takes place in an open system where alkaline rock or other alkaline substances are added to the surface ocean enabling it to absorb additional CO₂ over time. The CO₂ removal process occurs in the open ocean in an uncontrolled fashion.

³ The DOC method takes place via degassing (and thereafter, durably sequestering, in geological subsurface reservoirs) CO₂ dissolved in seawater. The CO₂ impoverished water is then returned to the ocean, allowing the seawater to re-equilibrate and absorb CO₂ from the atmosphere over time. As with OAE, the CO₂ re-equilibration process occurs in the open ocean in an uncontrolled fashion. Note that although CO₂ is initially extracted in a closed system, that CO₂ was already durably stored as dissolved inorganic species in the seawater, and the actual CO₂ removal occurs during the subsequent re-equilibration in the open ocean.

alkaline rock which re-alkalinizes it, while the alkaline seawater is utilized to capture CO₂ from the atmosphere and store additional CO₂ as aqueous bicarbonates and solid carbonates. Solid carbonates are separated (as governed by local discharge limits) and the two seawater streams are then combined. The re-equilibrated seawater is discharged back into the ocean. This process is depicted in more detail in [Figure 1.2](#).

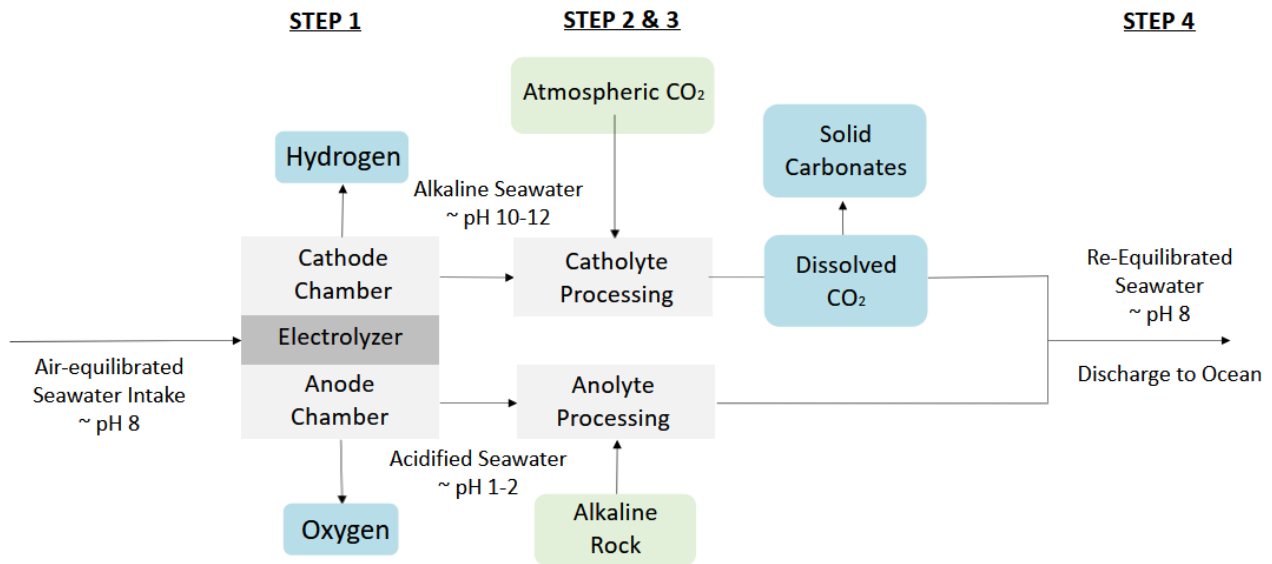

Figure 1.2 The DACOS process diagram

The electrochemical process operates by flowing seawater over/through electrode surfaces, applying a current at the cathode (the electrode with a negative charge), and producing carbonate and hydroxide mineral precipitates. The next step is catholyte processing where, due to the increased alkalinity, the seawater reacts with atmospheric CO₂ drawn out of the surrounding air. Here, CO₂ dissolves in water where it reacts with magnesium hydroxide and calcium ions present in the catholyte through a process called carbonation to form carbonate and bicarbonate ions and carbonate solids (La Plante et al., 2023), returning the pH of the seawater to near its original value. The seawater, now enriched with carbonate and bicarbonate ions, is ultimately discharged back to the ocean, while the separated solids are stored or utilized on land.

In more detail, the electrochemical process can be separated into four distinct steps (see [Figure 1.2](#)), which are outlined below.

Step 1

Air equilibrated seawater is supplied into an electrolyzer where it is separated into a cathode and an anode chamber.⁴ At the cathode, elevated alkalinity increases the pH to about 10-12 resulting in the production of alkaline seawater and hydrogen gas, and the precipitation of magnesium hydroxide (Mg(OH)₂) and calcium carbonate (CaCO₃). At the anode, reduced alkalinity decreases

⁴ In an electrochemical cell, the cathode is the negatively charged electrode (where reduction occurs), and anode is the positively charged electrode (where oxidation occurs).

the pH to 1-2 resulting in the production of oxygen gas (O₂). In many applications of seawater electrolysis, the presence of chloride ions (Cl⁻) in the water enables a reaction producing harmful chlorine gas (Cl₂) or other chlorine compounds to compete with the oxygen evolution reaction (OER) at the anode. However, utilizing OER-selective anodes mitigates the production of chlorine gas (Harvey et al., 2024).

Step 2

A stream of atmospheric CO₂ with a CO₂ concentration of roughly 420 parts per million ($x_{\text{CO}_2} \approx 420 \text{ ppm}$)⁵ is introduced to the alkaline seawater from the cathode, where the elevated pH causes increases in dissolved inorganic carbon species of bicarbonate and carbonate ions. The introduction of atmospheric CO₂ further results in the dissolution of the precipitated magnesium hydroxide and further precipitation of mineral carbonates. Upon the completion of the reactions, the seawater returns to a re-equilibrated state.

Step 3

Occurring concurrently with step 2, the acidified seawater from the anode is processed with ground alkaline rock in a closed system, replenishing the deficit of cations, returning the processed seawater to a re-equilibrated state.

Step 4

Most of the calcium carbonate solids processed from the catholyte stream are separated and removed before discharge to comply with environmental discharge limits. The now re-equilibrated anolyte and catholyte streams are discharged into the ocean.

1.4 Mechanism of carbon sequestration

The ocean as a carbon reservoir

The ocean is by far the largest reservoir of carbon dioxide in the climate system, containing around 38 000 Gt of carbon,⁶ or about 90% of all above-surface reservoirs (Ciais et al., 2013; Sabine & Tanhua, 2010). Furthermore, the ocean is also one of the most important carbon sinks (along with soil and vegetation), absorbing around a quarter of all CO₂ emissions generated by human activity each year (Watson et al., 2020). In total, the ocean contains approximately 50 times more carbon molecules than the atmospheric reservoir (Jones et al., 2014).

The reason why the ocean is able to hold so much more carbon than the other above-surface reservoirs lies in the ability of CO₂ to efficiently dissolve in seawater (equation (1.1)), where it reacts

⁵ The concentration of carbon dioxide in air is often reported as a dry air mole fraction (x_{CO_2}), which is defined as the number of CO₂ molecules in the air divided by the number of all molecules in the air excluding water vapour. The mole fraction is useful as the number of particles is independent of external factors such as temperature or pressure.

⁶ The oceans contain about 38 000 GtC as dissolved inorganic carbon (i.e. carbon dioxide and its derivatives). There are a further 700 GtC as dissolved organic carbon (e.g. soluble organic particles released by living organisms such as plants or algae), and 1750 GtC stored in minerals and organic matter on the ocean floor sediments. Living marine organisms constitute only a minor pool of carbon totalling around 3 GtC (Ciais et al., 2013; Friedlingstein et al., 2020).

forming carbonic acid (H_2CO_3) and its dissociation products, i.e. bicarbonate (HCO_3^-) and carbonate (CO_3^{2-}) ions (equations (1.2)–(1.4)). This system of chemical reactions can be summarized as⁷

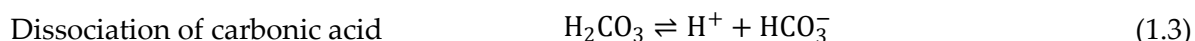
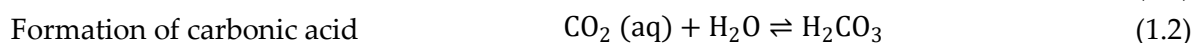
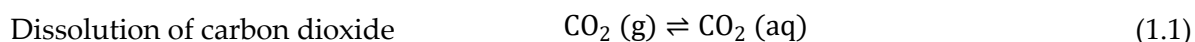

or more succinctly as

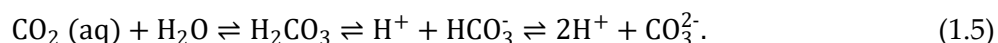

It is important to notice that there are significant differences in the equilibration time scales and concentrations of the above reactions. While the disassociation reactions are relatively fast and the carbonate species can often be assumed to be in equilibrium, the exchange of carbon dioxide between the surface ocean and the lower atmosphere (i.e. the air-sea gas exchange) is much slower, and generally occurs on annual timescales (Doney et al., 2009; Jones et al., 2014; Sabine & Tanhua, 2010), although significant local variance exists depending on factors such as depth of the mixed layer, wind speed, and carbonate chemistry (Jones et al., 2014). Hence, on a global scale, the surface water CO_2 uptake tends to increase at around the same *rate* as CO_2 in the atmosphere (Takahashi et al., 2009), but once dissolved, various chemical, physical, and biological processes can lead to significant differences in local surface water CO_2 *concentrations*. Typically, around 90 % of the dissolved inorganic carbon in oceanic surface waters is in the form of bicarbonate (HCO_3^-), and 9 % as carbonate (CO_3^{2-}) (Sabine & Tanhua, 2010). The remaining 1 % is mainly comprised of dissolved CO_2 , as the amount of carbonic acid (H_2CO_3) in aqueous solutions is negligible in comparison (Wolf-Gladrow et al., 2007).

Note that the natural uptake of CO_2 also results in the release of acidity (H^+ ions) into the ocean (equations (1.3) and (1.4)), which increases ocean acidification over time (E.U. Copernicus Marine Service Information, 2023; Zeebe, 2012). The increased acidity causes carbonate ions to be relatively less abundant, which can have detrimental effects to marine life such as oysters, clams, sea urchins, corals, calcareous plankton, and other organisms relying on carbonate minerals as building blocks for shells and support structures (Zeebe, 2012).

Baseline carbon removal in the oceans

The CO_2 in the atmosphere is in equilibrium with the CO_2 dissolved in the oceans: an increase in the atmospheric CO_2 concentration leads to increased oceanic CO_2 uptake and vice versa.⁸ The driving factor behind the net transfer of CO_2 across the sea surface is the difference between the partial pressures of CO_2 in the seawater and the overlying air, i.e.

$$\Delta p\text{CO}_2 = (p\text{CO}_2)_{\text{water}} - (p\text{CO}_2)_{\text{air}}, \quad (1.6)$$

⁷ Where confusion might occur, the following symbols are used in chemical formulas to represent the states of aggregation of chemical species: (aq) aqueous solution, (g) gas or vapor, (l) liquid, (s) solid.

⁸ This is an instance of the well-known Henry's law, according to which the amount of dissolved gas in a liquid is directly proportional to its partial pressure above the liquid.

where $\Delta p\text{CO}_2$ is the pressure difference, and $(p\text{CO}_2)_{\text{water}}$ and $(p\text{CO}_2)_{\text{air}}$ are the partial pressures⁹ of CO_2 in the water and air, respectively (Takahashi et al., 2009). Wherever $\Delta p\text{CO}_2$ is negative, i.e., $(p\text{CO}_2)_{\text{air}}$ is greater than $(p\text{CO}_2)_{\text{water}}$, there is a net influx of CO_2 from the air into the sea. On the other hand, if $(p\text{CO}_2)_{\text{water}}$ is greater, carbon dioxide tends to predominantly degas back into the atmosphere, and the seawater becomes a net source of CO_2 .¹⁰

On a global scale, the ocean is a net sink for CO_2 : during the last decade (2010–2019), the mean uptake was about 9.2 Gt CO_2 /yr, but this number has been on the rise since at least the 1960s due to the rise in global emissions (Canadell et al., 2021). In the Baseline case (i.e. without the DACOS process), the above-described natural air-sea gas exchange will continue unaffected: in the DACOS process, the outflowing seawater has been re-equilibrated during the electrochemical processing, and does not therefore negatively affect the partial pressure difference across the air-sea boundary (equation (1.6)).

Baseline carbon removal due to rock weathering

As described above, the DACOS process does not negatively affect the natural CO_2 removal in the oceans. However, the DACOS process might impact another natural CO_2 removal pathway known as (chemical) rock weathering, through consumption of alkaline rocks during the electrochemical processing step.

Chemical rock weathering is a natural phenomenon which removes about 1.1 Gt of CO_2 from the atmosphere each year (Strefler et al., 2018). In this process, carbon dioxide from the atmosphere first dissolves in water (e.g. rain droplets), and when this carbonated water comes into contact with rocks, it will react with—and eventually dissolve—the minerals contained in them. Over the course of these chemical reactions, the carbon dioxide that was dissolved in the water is sequestered as bicarbonates and carbonates, preventing the release of CO_2 back into the atmosphere.

It is well known that the above-described chemical weathering process may take place naturally under ambient environmental conditions in various feedstock materials, including mine wastes and tailings (Lechat et al., 2016; Pullin et al., 2019; Renforth, 2019; Wilson et al., 2014). For example, it has been estimated that the alkaline tailings from the Mount Keith nickel mine in Australia sequester atmospheric CO_2 at a gross rate of around 40 kt CO_2 /yr (Wilson et al., 2014).

During the anolyte processing step (see Figure 1.2), the DACOS process consumes alkaline rock, which is therefore unavailable to sequester carbon through the natural weathering process. However, the natural process is slow¹¹ and requires contact with water and the atmosphere to occur

⁹ In a mixture of gases, the partial pressure refers to the pressure exerted by an individual gas (i.e. the pressure an individual gas would have if it occupied the total volume alone). For CO_2 dissolved in seawater, the partial pressure refers to the CO_2 vapor pressure, or the partial pressure of CO_2 in the overlying air which would be in equilibrium with the dissolved gas (i.e. keep the amount of dissolved CO_2 constant).

¹⁰ The fact that the partial pressure depends sensitively on e.g. temperature leads to large local differences in CO_2 fluxes across the sea surface. For example, the equatorial Pacific Ocean is a major net source of atmospheric CO_2 , while the more temperate oceans away from the equator on both hemispheres are the major net sinks (Takahashi et al., 2009).

¹¹ The dissolution rates of minerals are highly dependent on the type of mineral and its reactive surface area as well as environmental factors such as pH, and the time it takes for e.g. a 1 mm mineral particle to dissolve can range from years or decades to millions of years depending on the mineral (Hartmann et al., 2013).

(Hartmann et al., 2013). Therefore, natural CO₂ removal through the Baseline chemical weathering process is only relevant in the case where the DACOS process utilizes relatively finely ground rock that had already been mined and stored under ambient conditions (e.g. quarry wastes and tailings), where the increased surface area as well as exposure to the elements expedite the weathering process. In those cases, the CO₂ Removal Supplier must quantify and account for the impact of rock weathering in the Baseline of carbon stored (see [section 4.7](#)).

Additional carbon removal by the DACOS process

The DACOS process can accelerate the ocean carbon uptake (La Plante et al., 2021, 2023). The additional CO₂ removal results from the electrochemical processing, which removes of carbon dioxide from the air, storing a major part of the CO₂ as dissolved inorganic carbon in the seawater, and a minor part as solid carbonates. The seawater is ultimately returned to the ocean, sequestering the dissolved carbonate species (predominantly bicarbonate, HCO₃⁻) in a highly durable fashion (Renforth & Henderson, 2017). Furthermore, note that the DACOS process does not contribute to ocean acidification as the pH of the discharge water exiting the reactor is monitored and controlled to be similar to ambient conditions.

The solid carbonates (e.g. calcium carbonate, CaCO₃) produced via this process are removed and stored offsite. As long as the solids do not encounter acid or extreme temperatures, they remain stable over very long periods of time ensuring that the CO₂ is not re-released into the environment (Sundquist, 1985).

2 Point of creation of the CO₂ Removal Certificate (CORC)

2.1 CO₂ Removal Supplier

2.1.1 The CO₂ Removal Supplier is the party contractually authorized to represent the participants necessary to perform the end-to-end activities associated with a Direct Air Capture and Ocean Storage (DACOS) activity seeking certification under this methodology (see also [section 3.3](#)).

2.2 Production Facility and Crediting Period

2.2.1 The Production Facility is the closed system necessary to perform the end-to-end activities associated with a DACOS activity, and subject to the Production Facility Audit.¹² For the purposes of this methodology, the Production Facility corresponds to the electrochemical processing facility and associated *balance of plant* (i.e. the various supporting components and auxiliary systems such as the catholyte and anolyte processing equipment) in the sense of [rule 3.2.4](#). The Production Facility shall include one or several electrolyzer modules located in the same site and subject to the same regulation.

2.2.2 The Crediting Period in this methodology is 15 years starting from the first date of the first monitoring period. The Crediting Period can be renewed twice by successfully undergoing a new Production Facility Audit. The Crediting Period shall not overlap with another Crediting Period.

2.3 Point of creation

2.3.1 The point of creation of the CO₂ Removal Certificate (CORCs) is defined as the earliest point in the CO₂ Removal process when carbon has been durably sequestered and CORCs can be claimed. For this methodology, the point of creation of the CO₂ Removal Certificate (CORC) is the moment when the CO₂ charged seawater has been returned to ocean at equilibrium state, and the complete data trail of the DACOS process can be verified.

¹² For more information regarding auditing, please see the Puro Standard General Rules, available in the [Puro Standard documents library](#).

3 Eligibility requirements

3.1 Overview

In broad terms, an eligible activity is capable of permanently increasing the oceanic and mineral carbon stocks by safely and durably storing atmospheric CO₂ as dissolved inorganic carbon in the ocean and as solid mineral carbonates. In practice, CO₂ Removal is achieved via electrochemical processing of seawater followed by the direct air contact to achieve re-equilibration inside of the facility. In addition to removing CO₂ from the atmosphere, the electrochemical processing of seawater co-produces hydrogen (H₂).

3.2 General eligibility

3.2.1 An **eligible activity** is an activity which utilizes electrochemical processing of seawater to capture and sequester atmospheric CO₂ as dissolved inorganic carbon and solid carbonate minerals under conditions which enable the safe and durable storage of CO₂, prevent the re-emission of CO₂ back to the atmosphere for at least 1000 years (see [rule 8.3.3](#)). The eligibility of the activity shall be determined during the Production Facility Audit.

3.2.2 The electrochemical processing of seawater shall include at least the following general process steps (see [Figure 1.2](#) for an illustration):

- a. Intake of equilibrated seawater.¹³
- b. Electrolysis of seawater to produce an alkaline and an acidic water stream.
- c. Sequestration of CO₂ from the ambient air into the alkaline water stream as dissolved inorganic carbon, or as solid carbonate minerals. Solid carbonate minerals in excess of local regulations shall be separated and stored on land (see [rule 3.2.3](#)).
- d. Dissolution of alkaline rock or minerals into the acidic water stream.
- e. Recombination and re-equilibration of the water streams.
- f. Discharge of re-equilibrated processed seawater.

¹³ For the purposes of this methodology, *equilibrated seawater* refers to seawater in which the CO₂ absorption/desorption reaction (equation (1.1)) is in chemical equilibrium, and whose pH and other chemical properties are consistent with the ambient seawater.

- 3.2.3 Solid carbonate minerals formed during the electrochemical processing of seawater may be incorporated into the discharge water stream to the extent allowed by the local environmental or other regulations. The CO₂ Removal Supplier shall separate from the processed seawater any solid carbonate minerals in excess of the quantities defined in these regulations and store the minerals in a dedicated storage site on land (see [section 3.4](#)).
- 3.2.4 The electrochemical processing of seawater shall take place in a dedicated facility, within a closed system reactor in a manner which enables the monitoring and control of the process inputs, outputs, and parameters to the extent defined in this methodology.
- 3.2.5 The chemical reactions that sequester CO₂ shall occur entirely within the confines of the closed-system electrochemical processing facility (see [rule 3.2.4](#)). Any potential subsequent CO₂ removal in the environment following the electrochemical processing stage is not eligible for crediting under this methodology. Examples of such ineligible CO₂ removal pathways include:
- a. Any CO₂ removal in the open ocean due to an elevated pH of the discharge seawater (alkalinity enhancement).
 - b. Chemical weathering of any stored carbonate minerals (enhanced weathering).
 - c. Any other similar open-system processes.
- 3.2.6 All installations and operations relating to the DACOS activity shall comply with all applicable local laws, regulations, and other statutory requirements.
- 3.2.7 All equipment shall be constructed, installed, and operated in accordance with national or industry best practices and in compliance with local statutory requirements. All installations shall be approved by the competent local authority or regulatory body and hold relevant permits for their operation.
- 3.2.8 To be considered eligible, the DACOS activity as a whole must be net negative, meaning that the total net amount of CO₂ stored (amount of CORCs) is greater than zero (i.e. that the gross amount of CO₂ stored is greater than the sum of CO₂ equivalent process emissions, indirect emissions, losses and Baseline carbon storage, see [rule 4.2.1](#)).

3.3 CO₂ Removal Supplier

- 3.3.1 The CO₂ Removal Supplier is responsible for fulfilling the requirements and obligations defined for CO₂ Removal Suppliers in Puro Standard General Rules and other Puro Standard Documents.¹⁴

¹⁴ Available in the [Puro Standard documents library](#).

- 3.3.2 The CO₂ Removal Supplier is responsible for ensuring that sufficient data is available and accessible for auditing and verification that the DACOS activity is compliant with the requirements of this methodology and other applicable Puro Standard Requirements, as well as any applicable local laws, regulations, and other binding obligations. This includes but is not limited to delivering the necessary data to assess the eligibility of the activity and to quantify the net carbon removal. In particular, the CO₂ Removal Supplier shall provide all calculation functions and parameters utilized for the quantification of net CO₂ Removal in a clear and consistent manner.
- 3.3.3 The CO₂ Removal Supplier shall provide a certified trade registry extract or similar official document stating that it is validly existing and in compliance with the legislation of the host jurisdiction.
- 3.3.4 The CO₂ Removal Supplier shall clearly establish and demonstrate the ownership of the CO₂ Removal project through either proof of direct ownership (in the form of contracts, authorization documents, or similar legally enforceable documents), or through contracts with external operators¹⁵ where relevant.
- 3.3.5 The CO₂ Removal Supplier shall provide, where applicable, evidence of valid permits, authorizations, licenses, or other equivalent regulatory control documents to operate any industrial facilities within the activity boundary. The CO₂ Removal Supplier shall furthermore provide evidence of possessing the rights to allow for appropriate monitoring at any stage within the activity boundary.

3.4 End of Use or Disposal of Carbonate Minerals

- 3.4.1 The CO₂ Removal Supplier shall provide a **statement of end use** for any extracted carbonate minerals.¹⁶ The statement of end use shall detail how the permanence of the CO₂ storage is ensured by the end use conditions (see also [rules 3.4.2–3.4.4](#) about risk assessment and mitigation, long-term storage planning, and major risks to permanence). The statement shall at least specify:
- a. The intended end use of the carbonated material (e.g. whether utilized in construction materials or other products, or stored permanently).
 - b. The storage conditions of any carbonated material intended for permanent storage (e.g. the type, location, and general properties of the permanent storage site).

¹⁵ For the purposes of this methodology, an external operator is defined as any party (such as a logistics operators, or an industrial site operator) operating on behalf and at the direction of the CO₂ Removal Supplier for provision of services relating to the DACOS activity.

¹⁶ For the purposes of this methodology, extracted carbonate minerals refers to any solid carbonate minerals extracted from the seawater stream during the electrochemical and catholyte processing stages, and deposited or utilized on land, as opposed to any carbonate mineral particulates discharged to the ocean from the electrochemical processing facility.

- c. A description of any products where the carbonated material is intended to be utilized, including the estimated lifetime and end of life use of the products.

3.4.2 The CO₂ Removal Supplier shall provide a **risk assessment and mitigation plan** for the risks related to the permanence of the CO₂ sequestration and potential re-emission of CO₂ from the extracted carbonate minerals. The risk assessment shall be comprehensive and specific to the intended end use of the extracted carbonate minerals. The risk assessment and mitigation plan shall at least address:

- a. Risks for exposure to chemical or physical conditions affecting storage permanence (see also [rule 3.4.4](#)).
- b. Risks related to the destruction, re-purposing, or other end of life use of any product(s) where the carbonated material is intended to be utilized.¹⁷
- c. Risks related to any potential major changes in the storage conditions of any carbonated material intended for permanent storage, such as due to e.g. decommissioning or destruction of the storage site (see also [rule 3.4.3](#)).

Furthermore, the risk assessment and mitigation plan shall include at least a qualitative estimation of the likelihood of each of the risks identified, and an outline of the measures in place to mitigate the effects to re-emission of the sequestered CO₂.

3.4.3 The CO₂ Removal Supplier shall provide a **long-term storage plan** for any extracted carbonate minerals intended for permanent storage. The long-term storage plan shall specify the measures in place to ensure the permanence of the carbonate minerals during storage, taking into account the identified risks (see [rule 3.4.2](#)). Furthermore, the long-term storage plan shall also specify how the permanence of the carbonated material is ensured in cases where:

- a. The CO₂ Removal Supplier ceases to exist as a legal entity.
- b. The ownership of the storage site and/or the stored carbonated material is transferred to a third party.
- c. The storage site is destroyed or decommissioned (e.g. as a part of land remediation or similar).

¹⁷ Specifically, it is noted that in cases where carbonate minerals are utilized in construction materials, the demolishing of such materials at end of life does not under normal circumstances lead to the re-emission of the stored carbon dioxide. The crushed material can be reused e.g. in road construction or in new carbonated products without the sequestered CO₂ being re-emitted to the atmosphere.

- 3.4.4 The extracted carbonates shall not be exposed to conditions resulting in the reversal of CO₂ sequestration, nor utilized for purposes where exposure to such conditions can occur. Such conditions include e.g. high temperatures where carbonates start to thermally decompose, or exposure to strong acids.¹⁸

3.5 CO₂ removal Baseline demonstration

The CO₂ removal Baseline is a conservative scenario of likely carbon removal that would have happened without the DACOS activity, and revenues from carbon finance. The CO₂ removal Baseline affects the determination of additionality (see [section 3.6](#)) and quantification of CO₂ stored (see [sections 4.1](#) and [4.7](#)).

- 3.5.1 For the purposes of this methodology, the CO₂ removal Baseline scenario is that the DACOS activity does not take place, and no additional infrastructure required for the activity (e.g. the electrochemical treatment plant) is built.
- 3.5.2 The amount of CO₂ removed in the Baseline scenario is assessed based on the Baseline removal processes further defined in [subrules a](#) and [b](#).
- a. **Baseline for ocean uptake of atmospheric carbon.** For all eligible activities, the natural ocean uptake of CO₂ is not inhibited compared with the Baseline scenario. Therefore, the Baseline CO₂ removal due to storage of CO₂ in the ocean is set to zero tonnes of CO₂ sequestered.
 - b. **Baseline for alkaline rock weathering.** The Baseline carbon sequestration due to chemical weathering of any alkaline rock or mineral feedstocks utilized during the electrochemical processing is determined in a project specific manner according to [rule 3.5.3](#).
- 3.5.3 The CO₂ Removal Supplier shall select the applicable Baseline for alkaline rock weathering from the options described in [subrules a](#) and [b](#). The CO₂ Removal Supplier shall furthermore demonstrate that the selected Baseline corresponds to project activities.
- a. **Purpose-mined rock.** This Baseline shall be utilized in cases where the alkaline rock or mineral feedstock is mined or quarried specifically for the purposes of the DACOS activity. In this Baseline scenario, the weathering and subsequent carbon removal of the unmined rock is considered insignificant due to the low reactive surface area of unmined rock. Therefore, the Baseline CO₂ removal is set to zero tonnes of CO₂ sequestered.

¹⁸ The precise thermal decomposition range for metal carbonates varies by species but is usually several hundred degrees centigrade for the carbonates relevant for this methodology, e.g. around 750 °C for CaCO₃ (Karunadasa et al., 2019).

- b. **Separately mined rock.** This Baseline shall be utilized in cases where the alkaline rock or mineral feedstock is the result from a separate mining or quarrying operation unrelated to the DACOS activity (e.g. utilization of mine tailings or other wastes). The CO₂ Removal Supplier shall estimate and account for the Baseline carbon removal due to chemical weathering of the alkaline rock according to the requirements in [section 4.7](#).

3.6 Additionality

Additionality is essential for the integrity and credibility of carbon crediting, as it ensures that the credits represent real and additional CO₂ removal that contributes to mitigating climate change. Additionality comprises of the three different aspects:

- **Regulatory additionality:** the activity is not required by existing laws, regulations, or other binding obligations.
- **Carbon additionality to the Baseline:** the activity results in higher volume of carbon removals than the likely Baseline alternatives.
- **Financial additionality:** the CO₂ removals are a result of the incentive provided by carbon credits.

3.6.1 The CO₂ Removal Supplier shall demonstrate additionality according to requirements detailed in the Puro Standard General Rules and Puro Additionality Assessment Requirements.¹⁹ Note that demonstrating additionality entails that the CO₂ Removal Supplier demonstrates that the DACOS activity fulfills *all of the following requirements*:

- a. The activity is not required by existing laws, regulations, or other binding obligations.
- b. The activity results in higher volumes of CO₂ removals than the likely Baseline scenario.
- c. The activity is financially additional.

3.7 Prevention of double counting

3.7.1 The CO₂ Removal Supplier shall ensure that the CO₂ removal is not double counted in a manner which would infringe the Puro Standard General Rules. In particular, the General Rules entail that:²⁰

¹⁹ Available in the [Puro Standard documents library](#).

²⁰ In the currently (Jan 2025) most recent version (Puro Standard General Rules v. 4.1), relevant requirements are listed in section 3.5 “Preventing Double Counting”

- a. The CO₂ Removal Supplier shall provide evidence that it has the sole right to claim CORCs from the CO₂ sequestered, and that other parties involved in the supply chain have no such right. This can be evidenced by contracts or attestations exhibiting the relation between the involved parties.
- b. The CO₂ Removal Supplier shall allocate emission to co-products (i.e. hydrogen, see [section 5.3](#)).
- c. The CO₂ Removal Supplier or any party involved in the supply chain shall not associate any CORCs (whether for marketing, branding, or footprint claim) to any other products or services delivered by the CO₂ Removal Supplier or involved party (including other types of environmental products, such as renewable energy certificates), unless the issued CORCs have been explicitly retired for this purpose.
- d. The CO₂ Removal Supplier or any party involved in the supply chain may still report their direct emissions and removals in other sectoral GHG inventories (e.g., mandatory national reporting for UNFCCC, or voluntary corporate reporting), making adequate disclosures regarding the issuance of CORCs.

3.8 Environmental and social safeguards

Note that the Puro Standard General Rules and other Standard documents contain the general requirements on environmental and social safeguards that apply to all methodologies (see also [rule 3.8.1](#)), while this section contains further details relevant to DACOS activities in particular. Further information and guidelines on how the CO₂ Removal Supplier complies with the general requirements for environmental and social safeguards detailed in the Puro Standard General Rules are given in the Environmental and Social Safeguards Questionnaire, the Stakeholder Engagement Requirements, and the Stakeholder Engagement Report template (available in the Puro Standard documents library).

3.8.1 The CO₂ Removal Supplier shall have in place, maintain, and abide by environmental and social safeguards to the extent required by this methodology, the Puro Standard General Rules and other Standard Requirements, international conventions,²¹ or any applicable local statutory requirements, in order to ensure that the carbon removal activities do no net harm to the surrounding natural environment, ocean ecology, or local communities.

²¹ For example, the Convention on the Prevention of Marine Pollution by Dumping of Wastes and Other Matter ([London Convention](#)) and the Protocol to that Convention (London Protocol)

- 3.8.2 The CO₂ Removal Supplier shall comply with all local laws and regulations related to the discharge of water and any other relevant substances (such as mineral carbonates) from the electrochemical processing facility (including, but not limited to effluent discharge limits for waterways, and other environmental regulations). Examples of such local regulations include:
- **United States Clean Water Act (CWA):** The CWA regulates the discharge of pollutants from all sources, including ships, into U.S. waters. It sets water quality standards and requires permits for any releases.
 - **European Union Marine Strategy Framework Directive (MSFD):** This directive aims to protect the marine environment and sets targets for good environmental status in the European Union. It includes rules on the discharge of pollutants and requires monitoring of marine waters.
 - **The Environmental Protection and Management Act (EPMA) in Singapore:** The primary legislation dealing with the issue of environmental pollution control in the areas of air, water, and noise pollution in Singapore.
- 3.8.3 The CO₂ Removal Supplier shall comply with all applicable local laws and regulations relating to access and consumption of water resources. The CO₂ Removal Supplier shall furthermore recognize, respect and promote the human rights to safe drinking water and sanitation²² as well as the right to water as laid out in the General Comment No. 15 of the United Nations Committee on Economic, Social and Cultural Rights.²³ In particular, the CO₂ Removal Supplier shall not endanger the availability, quality, or accessibility of the local water supply, as defined in article 12 of General Comment No. 15.²⁴
- 3.8.4 The CO₂ Removal Supplier shall comply with all applicable local laws and regulations relating to gas emissions (including but not limited to compliance with all local regulatory limits).²⁵
- 3.8.5 The CO₂ Removal Supplier shall provide all environmental permits, assessments, and other documents related to the analysis and management of environmental and social impacts of the carbon removal activities that are required by the applicable local laws and regulations.
- 3.8.6 The CO₂ Removal Supplier shall undertake an assessment of the environmental and social impacts of the DACOS activity as further detailed in [subrules a](#) and [b](#):

²² The human rights to safe drinking water and sanitation, G.A. Res 78/206, [U.N. Doc. A/RES/78/206](#) (Dec. 22, 2023).

²³ General Comment No. 15 (2002), The right to water (arts. 11 and 12 of the International Covenant on Economic, Social and Cultural Rights), [U.N. Doc. E/C.12/2002/11](#) (Jan. 20, 2003).

²⁴ *Ibid.*, p. 5.

²⁵ For example, in the United States, such limits might be set by the Occupational Safety and Health Administration ([OSHA](#)), or other comparable regulatory bodies.

- a. The scope of the assessment shall cover all stages (alkaline rock sourcing, seawater processing, hydrogen production, and carbon removal) within the activity boundary (see [Figure 5.1](#)).
- b. The assessment shall include at least the following components:
 - (i) Description of the applicable legal and regulatory framework pertaining to the assessment and management of the environmental and social impacts of the DACOS activity.
 - (ii) Description of the existing local environmental and socio-economic conditions (i.e. background information on the current environmental and socio-economic context in which potential impacts are assessed, see also [rule 7.5.2](#)).
 - (iii) Description of the DACOS activity in detail, including construction, operation, and decommissioning of infrastructure, and other aspects affecting the assessment of environmental and social impacts, including any expected changes in project sites and in their vicinity over the lifetime of the activity.
 - (iv) Description any potential environmental effects and risks to marine and land-based ecosystems associated with:
 - Rapid or sudden changes in ocean chemistry (e.g. due to temporary process malfunction).
 - Pipelines, and pumping of the intake and discharge water.
 - Metal contamination from dissolution of alkaline rock.
 - Changes in water opacity and light conditions.
 - Changes in secondary mineral precipitation.
 - Disposal of the generated solid carbonates.
 - Decommissioning of the equipment.
 - (v) Description of any additional environmental and social impacts identified by the CO₂ Removal Supplier. For example, such impacts might include any potential negative effects to:
 - soil, air, and water quality,
 - flora and fauna,
 - human health and safety,

- socio-economic factors (e.g. related to land use or water resources),
- local communities (e.g. due to infrastructure construction, or noise and other similar nuisance factors), and
- culturally or ecologically sensitive areas (see also [rule 3.8.7](#)).

(vi) Description of the measures to mitigate the identified environmental and social impacts, including where relevant a description of the parameters and methods utilized to monitor the potential impacts.

(vii) Description of public participation and consultation.

To address the above components partly or in full, the CO₂ Removal Supplier may utilize and refer to other documents (e.g. project description documents, stakeholder engagement reports, or legally mandated environmental and social impact assessment documents) containing the required information, provided that such additional documents are also included.

3.8.7 The CO₂ Removal Supplier shall identify and avoid culturally, or ecologically sensitive areas as further detailed in [subrules a](#) and [b](#).

a. The CO₂ Removal Supplier shall conduct a comprehensive assessment (utilizing e.g. field surveys and existing data and maps) to identify any culturally or ecologically sensitive areas within the spatial boundaries of the project, such as:

(i) Sites of cultural significance (e.g. archaeological sites, burial grounds, and sacred places).

(ii) Ecologically sensitive areas (e.g. wetlands, seagrass beds, coral reefs, and habitats for endangered and threatened species).

b. The CO₂ Removal Supplier shall not operate on any areas that have been identified as culturally or ecologically sensitive.

3.8.8 The CO₂ Removal Supplier shall have in place and maintain instructions for occupational health and safety for all employees under the direction of the CO₂ Removal Supplier (regardless of whether employed directly by the CO₂ Removal Supplier or through a contractor), and ensure that the instructions are followed.

3.8.9 The CO₂ Removal Supplier shall record and disclose to the Issuing Body any negative environmental or social impacts (or claims thereof) occurred during the monitoring period, including but not limited to any legal actions and/or other written complaints filed by affected parties.

3.9 Requirements for positive sustainable development goals impacts

The Puro Standard General Rules and the associated SDG Assessment Requirements²⁶ contain the general requirements related to describing and evidencing positive impacts on Sustainable Development Goals (SDGs)²⁷ that apply to all methodologies. Examples of potentially relevant SDG targets²⁸ for DACOS activities include:

- **SDG 7.A:** *By 2030, enhance international cooperation to facilitate access to clean energy research and technology, including renewable energy, energy efficiency and advanced and cleaner fossil-fuel technology, and promote investment in energy infrastructure and clean energy technology.*
 - Production of green hydrogen can catalyze the hydrogen economy and promote investment in energy infrastructure and clean energy technology, in-turn increasing clean energy enterprise creation and contracting.
- **SDG 8.2:** *Achieve higher levels of economic productivity through diversification, technological upgrading and innovation, including through a focus on high-value added and labour-intensive sectors.*
 - The DACOS activities are well suited to drive economic productivity through diversification, technology upgrading and innovation.
- **SDG 9.4:** *By 2030, upgrade infrastructure and retrofit industries to make them sustainable, with increased resource-use efficiency and greater adoption of clean and environmentally sound technologies and industrial processes, with all countries taking action in accordance with their respective capabilities.*
 - The DACOS activities might encompass e.g. upgrading of desalination plants to make them sustainable and operate with increased resource-use efficiency.
- **SDG 17.7:** *Promote the development, transfer, dissemination and diffusion of environmentally sound technologies to developing countries on favourable terms, including on concessional and preferential terms, as mutually agreed.*
 - Partnering with local organizations to promote community involvement in carbon dioxide removal can advance the development, transfer, dissemination and diffusion of environmentally sound technologies between high- and low-/middle-income countries.

²⁶ Available in the [Puro Standard documents library](#).

²⁷ Resolution adopted by the General Assembly on Work of the Statistical Commission pertaining to the 2030 Agenda for Sustainable Development, G.A. Res 78/206, [U.N. Doc. A/RES/71/313](#) (Jul. 6, 2017). Note that this original SDG indicator framework is subject to regular updates and has since been revised several times.

²⁸ For a list of currently up to date SDG targets, see the [current official SDG indicator list](#) hosted at the United Nations Statistics Division website. Furthermore, the United Nations Department of Economic and Social Affairs website provides a [browsable SDG indicator list](#).

- 3.9.1 The CO₂ Removal Supplier shall provide descriptions, evidence, and information on the positive impacts of the DACOS activity on Sustainable Development Goals in accordance with the Puro Standard General Rules and other Standard Requirements (in particular the Puro Standard SDG Assessment Requirements). Specifically, the Puro Standard General Rules entail that:
- a. The CO₂ Removal Supplier shall provide **qualitative descriptions** of expected positive impacts on Sustainable Development Goals (SDGs) before the Production Facility Audit.
 - b. The CO₂ Removal Supplier shall provide **qualitative and quantitative evidence** of positive impacts on SDGs for the Output Audit based on the SDG Assessment Requirements
 - c. The CO₂ Removal Supplier shall, where feasible, provide **information** on how the DACOS activity is consistent with the relevant SDG objectives of the host country.

4 Quantification of CO₂ Removal Certificates (CORCs)

4.1 Overview

In general, a CORC represents 1 tonne CO₂e net removal from the atmosphere. In the specific case of DACOS, the CO₂ removal results from the electrochemical removal of existing CO₂ from seawater²⁹ and carbonation of the processed seawater to remove CO₂ from the atmosphere which is stored in the ocean as dissolved inorganic carbon (DIC) and as solid carbonates, and on land as solid carbonates.

The overall principle of the CORC calculation (see Figure 4.1) is that the CO₂ Removal Supplier first determines the gross amount (in metric tonnes) of CO₂ captured (C_{stored}) by the production facility over a given monitoring period. Various deductions are then made, such as losses of CO₂ removal (C_{loss}), supply chain *emissions* (E_{project}), any unmitigated *indirect emissions* outside of the project (E_{indirect}), and Baseline CO₂ removal ($C_{\text{baseline removal}}$). The resulting net amount of carbon sequestered is converted to CO₂ equivalents and credited as CORCs. More details on the method of calculation are given in this section. For ease of reference, a summary of the variables utilized in this section can be found in Table 4.1 at the end of this section.

	$\underbrace{\text{CORCs}}_{\text{Net amount of CO}_2\text{-eq removed by the DACOS activity during the reporting period.}}$	$=$	$\underbrace{C_{\text{stored}}}_{\text{Gross amount of eligible CO}_2\text{ stored in dissolved bicarbonates and solid carbonate minerals.}}$	$-$	$\underbrace{C_{\text{baseline removal}}}_{\text{Total amount of CO}_2\text{-eq which would have been stored in the absence of the removal activity, if any.}}$	$-$	$\underbrace{C_{\text{loss}}}_{\text{Total losses of CO}_2\text{ removal due to e.g. degassing or precipitation, if any.}}$	$-$	$\underbrace{E_{\text{project}}}_{\text{Total life cycle emissions arising from the whole supply chain of the DACOS activity.}}$	$-$	$\underbrace{E_{\text{indirect}}}_{\text{Total GHG emissions due to unmitigated negative ecological, market and activity-shifting leakage.}}$
Units	Tonnes of CO ₂ e		Tonnes of CO ₂ e		Tonnes of CO ₂ e		Tonnes of CO ₂ e		Tonnes of CO ₂ e		Tonnes of CO ₂ e

Figure 4.1 The CORC calculation equation.

4.2 Overall equation

4.2.1 The overall number of CORCs (i.e., the total net amount of CO₂ removed) during a monitoring period shall be calculated as follows (see also Figure 4.1 for an illustration):

$$\text{CORCs} = C_{\text{stored}} - C_{\text{baseline removal}} - C_{\text{loss}} - E_{\text{project}} - E_{\text{indirect}} \quad (4.1)$$

²⁹ Small amounts of solid calcium carbonate (CaCO₃) can form in the electrolyzer (i.e. during step 1 in Figure 1.2), amounting to removal of DIC from seawater. This removed DIC is replaced in a later processing step through the dissolution of CO₂ from the ambient atmosphere.

Variable	Description	Unit
CORCS	Net amount of CO ₂ equivalents removed by the direct air capture and ocean storage activity.	tCO ₂ e
C _{stored}	The gross amount of eligible CO ₂ stored in solid carbonates or dissolved bicarbonates. Further requirements on the calculation of this term are given in section 4.3 .	tCO ₂ e
C _{baseline removal}	The total amount of CO ₂ that would have been stored (naturally or man-made) in the absence of the removal activity. Further requirements on the calculation of this term are given in section 4.7 .	tCO ₂ e
C _{loss}	Losses of CO ₂ removal due to degassing, precipitation, or other pathways. Further requirements on the calculation of this term are given in section 4.6 .	tCO ₂ e
E _{project}	Life cycle emissions arising from the whole supply chain of the direct air capture and ocean storage activity and allocated to the carbon removal project. Further requirements on the calculation of this term are given in section 4.4 .	tCO ₂ e
E _{indirect}	Indirect GHG emissions due to unmitigated negative ecological, market, and activity-shifting leakage or indirect emissions resulting from the direct air capture and ocean storage activity. Further requirements on the calculation of this term are given in section 4.5 .	tCO ₂ e

4.3 Carbon dioxide stored (C_{stored})

Dissolved species

During carbonation, an increase in dissolved inorganic carbon (DIC) will occur, which is directly associated with CO₂ removal and dependent on the establishment of equilibrium. The increase in DIC between the seawater intake and discharge (i.e. between Point A and Point E in [Figure 7.2](#)) represents the amount of CO₂ pulled into the system in dissolved forms resulting from the carbonation of the alkaline catholyte stream.

The increase in DIC can be measured either directly or calculated from other measured parameters (i.e., proxy measurements). Such proxy measurements are particularly useful in cases where direct measurements of DIC are not possible or feasible. This method relies on continuous measurements of pH and pCO₂ together with measurements of total alkalinity, temperature, and salinity to estimate DIC by calculating the chemical speciation in the equilibrated carbonate system (see [equations \(1.1\)–\(1.4\)](#)) using geochemical modeling software such as PHREEQC (Parkhurst & Appelo, 2013). This method provides continuous monitoring but has reduced accuracy compared to quantification via direct DIC measurements.

Solid species

During the DACOS activity, carbon can also be sequestered as several different solid carbonate minerals (aragonite, calcite, hydromagnesite, nesquehonite, and dypingite, see Table 4.1). The amount of solid species formed can be quantified either by directly weighing the solids, or by monitoring the mass flow of the alkaline-earth metals contained in the minerals (i.e. Ca and Mg) between the seawater intake and solid separation (i.e. between Point A and Point D in Figure 7.2). For the quantification of carbon contained in solid species, the amount of CO₂ sequestered in each mineral phase is first calculated, taking into account the different CO₂ sequestration potentials of the specific mineral species formed. The total carbon contained as solids species (CO_{2,solid}) is obtained as a summation over the different mineral phases formed (see rule 4.3.3).

Table 4.1. Properties of solid minerals relevant for carbon capture formed during the DACOS process.

Mineral	Composition	Molar mass (M _i) g/mol	CO ₂ factor (R _i) mol CO ₂ /mol mineral
Aragonite/Calcite	CaCO ₃	100.09	1
Hydromagnesite	Mg ₅ (CO ₃) ₄ (OH) ₂ ·4H ₂ O	467.64	0.8
Nesquehonite	MgCO ₃ ·3H ₂ O	138.36	1
Dypingite	Mg ₅ (CO ₃) ₄ (OH) ₂ ·5H ₂ O	485.65	0.8

4.3.1 The gross amount of eligible CO₂ stored (C_{stored}) shall be calculated as follows:

$$C_{\text{stored}} = CO_{2,\text{dissolved}} + CO_{2,\text{solid}} \tag{4.2}$$

Variable	Description	Unit
C _{stored}	Gross amount of eligible CO ₂ stored in the ocean as a result of the DACOS activity.	tCO ₂ e
CO _{2,dissolved}	Total amount of carbon contained as dissolved inorganic species as a product of the DACOS activity.	tCO ₂ e
CO _{2,solid}	Total amount of carbon contained as solids species as a product of the direct air capture and ocean storage activity.	tCO ₂ e

4.3.2 The CO₂ Removal Supplier shall quantify the total carbon contained as dissolved inorganic species (CO_{2,dissolved}) as follows.

$$CO_{2,\text{dissolved}} = \Delta DIC \times CDR_{\text{DIC}} \times F_{\text{avg}} \times SI \times M_{\text{CO}_2} \times 10^{-6} \frac{\text{tCO}_2\text{e}}{\text{gCO}_2\text{e}} \tag{4.3}$$

Variable	Description	Unit
CO _{2,dissolved}	Total carbon contained as dissolved inorganic species as a product of the DACOS activity.	tCO ₂ e

ΔDIC	The difference in dissolved inorganic carbon between the seawater intake and discharge (i.e. the increase in DIC from Point A to Point E in Figure 7.2).	mol/L
CDR_{DIC}	The amount of CO_2 removed per mol of DIC species (i.e. per mole of carbon contained in the various DIC species), $\text{CDR}_{\text{DIC}} = 1 \frac{\text{mol CO}_2\text{e}}{\text{mol C}}$.	$\frac{\text{mol CO}_2\text{e}}{\text{mol C}}$
F_{avg}	The average liquid flow rate in a minute.	L/min
SI	Sampling interval.	min
M_{CO_2}	The molar mass of CO_2 , $M_{\text{CO}_2} = 44.01 \frac{\text{g}}{\text{mol}}$.	g/mol

4.3.3 The CO_2 Removal Supplier shall quantify the increase in dissolved inorganic carbon between the seawater intake and discharge (ΔDIC) through either direct or indirect (proxy) measurement as further detailed in [subrules a](#) and [b](#).

- Whenever feasible, the CO_2 Removal Supplier shall quantify ΔDIC through direct measurement of DIC at Point A and Point E of the measuring schematic in [Figure 7.2](#).
- In cases where direct measurements of DIC are not possible or feasible, the CO_2 Removal Supplier shall quantify ΔDIC as follows, utilizing a geochemical modelling software (e.g. PHREEQC) to calculate the chemical speciation (i.e., the concentrations of $\text{CO}_{2(\text{aq})}$, HCO_3^- , CO_3^{2-} , and H_2CO_3) in the equilibrated carbonate system based on continuous measurements of pH and pCO_2 together with measurements of total alkalinity, temperature, and salinity.

$$\Delta\text{DIC} = \Delta\text{CO}_{2(\text{aq})} + \Delta\text{HCO}_3^- + \Delta\text{CO}_3^{2-} + \Delta\text{H}_2\text{CO}_3 \quad (4.4)$$

Variable	Description	Unit
ΔDIC	The difference in dissolved inorganic carbon between the seawater intake and discharge (i.e. the increase in DIC from Point A to Point E in Figure 7.2).	mol / L
$\Delta\text{CO}_{2(\text{aq})}$	The calculated difference in dissolved CO_2 between the seawater intake and discharge (i.e. from Point A to Point E in Figure 7.2).	mol / L
ΔHCO_3^-	The calculated difference in dissolved bicarbonate (HCO_3^-) between the seawater intake and discharge (i.e. from Point A to Point E in Figure 7.2).	mol / L
ΔCO_3^{2-}	The calculated difference in dissolved carbonate (CO_3^{2-}) between the seawater intake and discharge (i.e. from Point A to Point E in Figure 7.2).	mol / L

ΔH_2CO_3	The calculated difference in dissolved carbonic acid (H_2CO_3) between the seawater intake and discharge (i.e. from Point A to Point E in Figure 7.2). Note that due to its rapid dissociation, the concentration of H_2CO_3 is usually very low compared to the other species.	mol / L
------------------	--------------------------------------------------------------------------------------------------------------------------------------------------------------------------------------------------------------------------------------------------------------------------------------------------------	---------

4.3.4 The CO₂ Removal Supplier shall quantify the total carbon contained as solids species ($CO_{2,solid}$) as follows.

$$CO_{2,solid} = \sum_{i \in S} w_i \times R_i \times \frac{(m_{solids} - m_{water})}{M_i} \times M_{CO_2} \times 10^{-6} \frac{tCO_2e}{gCO_2e} \quad (4.5)$$

- a. For the quantification of solid carbonate minerals, the CO₂ Removal Supplier shall first separate all carbonate solids after catholyte carbonation for weighing and chemical analysis as further defined in [subrules b-e](#). Following quantification of the separated solids, the supplier may re-introduce carbonate solids to the discharge water stream to the extent allowed by local environmental and other applicable regulations (see also [rule 3.2.3](#)).
- b. The CO₂ Removal Supplier shall determine the total weight of the solids produced via direct measurements utilizing reliable and calibrated weight measurement equipment, such as load cells or weighbridges.³⁰ For any solids transported to permanent storage, the record of the weight shall be documented on the bill of lading (BOL) for each pickup.
- c. The CO₂ Removal Supplier shall collect a grab sample of the separated solids for the determination of mineral phase distribution and water content through powder X-ray diffraction (XRD) analysis and thermogravimetric analysis (TGA).
- d. The CO₂ Removal Supplier shall determine the total mass of water contained in the separated solids (m_{water}) through thermogravimetric analysis (TGA).
- e. The CO₂ Removal Supplier shall determine mass fraction of each mineral phase contained in the separated solids (w_i) based X-ray diffraction (XRD) analysis (taking into account the water mass, see [subrule d](#)).
- f. The CO₂ Removal Supplier shall perform additional verification of the value of $CO_{2,solid}$ by comparing the value obtained from [equation \(4.5\)](#) to the value calculated in accordance with [rule 7.4.6](#).

³⁰ For example, weighbridges (e.g. truck scales) are highly accurate and well-maintained due to regulatory requirements, thus there is a high level of confidence in the accuracy of the total weight measurement.

Variable	Description	Unit
$CO_{2, \text{solid}}$	Total carbon contained as solids species	tCO ₂
w_i	Mass fraction of the particular mineral phase i as obtained by XRD	%mass
R_i	The molar ratio of CO ₂ removed per mol of mineral produced (see Table 4.1)	mol/mol
m_{solids}	The total mass of solids produced as obtained by truck scale with a weighbridge	g
m_{water}	The total mass of water in the solids as measured by TGA	g
M_i	Molar mass of the particular mineral phase i (see Table 4.1)	g/mol
M_{CO_2}	The molar mass of CO ₂ , $M_{CO_2} = 44.01 \frac{\text{g}}{\text{mol}}$	g/mol
i	Summation index (an element in the set of mineral phases S)	unitless
S	Set of carbonate mineral phases. For the purposes of this methodology, the set of mineral phases consists of the minerals listed in Table 4.1 (aragonite, calcite, hydromagnesite, nesquehonite, and dypingite).	unitless

4.4 Project emissions (E_{project})

The DACOS process results in two co-products: hydrogen and carbon removal. In this methodology, the term E_{total} refers to the total emissions (including hydrogen production and carbon removal) associated with the DACOS activity, while the project emissions (E_{project}) refer to the share of total emissions allocated to the carbon removal co-product. The CORCs are calculated based on the project emissions (E_{project}) as per rule 4.2.1.

4.4.1 The CO₂ Removal Supplier shall quantify the project emissions (E_{project}) based on a life cycle assessment (LCA) of the DACOS activity, according to the requirements and system boundaries defined in section 5 of this methodology.

4.4.2 The CO₂ Removal Supplier shall determine the project emissions (E_{project}) associated with the DACOS activity as follows.

$$E_{\text{project}} = E_{\text{total}} - E_{\text{H}_2} \quad (4.6)$$

Variable	Description	Unit
E_{project}	Life cycle emissions arising from the whole supply chain of the direct air capture and ocean storage activity and allocated to the carbon removal project.	tCO ₂ e
E_{total}	Total life cycle emissions arising from the whole supply chain of the direct air capture and ocean storage.	tCO ₂ e

E_{H_2}	Total life cycle emissions allocated to the production of low or zero carbon hydrogen. Further requirements on the calculation of this term are given in section 5.3 .	tCO ₂ e
-----------	----------------------------------------------------------------------------------------------------------------------------------------------------------------------------------------	--------------------

4.4.3 The CO₂ Removal Supplier shall determine the total emissions (E_{total}) associated with the DACOS process as follows.

$$E_{total} = E_{ops} + E_{emb} \tag{4.7}$$

Variable	Description	Unit
E_{total}	Total life cycle emissions arising from the whole supply chain of the direct air capture and ocean storage.	tCO ₂ e
E_{ops}	Total operational emissions during the monitoring period, resulting from the DACOS activity across the whole supply chain. Further requirements on the calculation of this term are given in section 5.2 (see esp. rule 5.2.6).	tCO ₂ e
E_{emb}	Total embodied emissions allocated to the monitoring period, resulting from the DACOS activity across the whole supply chain. Further requirements on the calculation of this term are given in section 5.2 (see esp. rule 5.2.14). Note that for the purposes of CORC calculation, the embodied emissions are amortized according to rule 5.2.16 .	tCO ₂ e

4.5 Ecological, market, and activity-shifting indirect emissions ($E_{indirect}$)

4.5.1 The CO₂ Removal Supplier shall quantify the total GHG emissions produced due to unmitigated negative indirect emissions (also known as *leakage*) resulting from DACOS activity as follows.

$$E_{indirect} = E_{ECO} + E_{MA} \tag{4.8}$$

Variable	Description	Unit
$E_{indirect}$	Total indirect GHG emissions due to unmitigated negative indirect emissions (also known as leakage) resulting from the DACOS activity.	tCO ₂ e
E_{ECO}	Total GHG emissions due to unmitigated indirect ecological emissions resulting from the DACOS activity (see also rule 6.4.1). Further requirements on the calculation of this term are given in section 6 .	tCO ₂ e
E_{MA}	Total GHG emissions due to unmitigated negative market and activity shifting resulting from the DACOS activity Further	tCO ₂ e

requirements on the calculation of this term are given in section 6.

4.6 Losses (C_{loss})

For the purposes of this methodology, *losses* of CO₂ removal refer to carbon losses from re-emission pathways known or assumed a priori, and which therefore need to be accounted for at the time of CORC issuance. Previously unknown or unanticipated re-emissions after issuance of CORCs are termed reversals and are accounted for via a procedure described in the Puro Standard general rules (see also [rule 4.6.1](#)).

The discharge of seawater with increased alkalinity may result in localized elevation of ocean pH, depending on factors such as the design of the DACOS facility and the hydrodynamics at the outfall. The increased alkalinity of the water may in turn result in unintended secondary precipitation of calcium carbonate (CaCO₃) in the ocean and the concurrent release of CO₂:

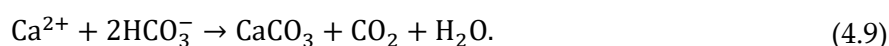

In this reaction, 1 mol of carbon dioxide is released for every mol of calcium carbonate precipitated. Note that because CaCO₃ precipitation consumes alkalinity, the efficiency of CO₂ absorption is decreased, as it is more efficient to stabilize atmospheric CO₂ as aqueous species compared to mineral carbonates. Carbonate precipitation could also change the Ca:Mg ratios locally and at short time scales. However, monitoring the pH of the discharge water can be utilized to assess the likelihood of secondary precipitation and ensure that excessive precipitation does not occur. Furthermore, simulations of ocean circulation have indicated that most regional stretches of coastline are able to accommodate 10s to 100s of megatonnes of CO₂ removal within 300 km of the coast (He & Tyka, 2023).

Some re-emissions may additionally occur during the electrochemical processing step itself. For example, a small amount of CO₂ may be degassed at the anode due to the generated acidity. However, the amount of degassed CO₂ is accounted for by the measurements of dissolved inorganic carbon of the *combined* processed anolyte and processed catholyte.

Note that besides the aforementioned loss pathways, further re-emissions might occur through *reversal events* (i.e. previously unknown or unanticipated re-emissions after issuance of CORCs, accounted for separately) such as industrial accidents. For example CO₂ might be released inadvertently during the DACOS process due to e.g. accidental mixing of unneutralized acid with the alkaline water stream.³¹

³¹ Note that as such industrial accidents are not expected to happen under normal circumstances, they correspond to unexpected *reversals* rather than the known or assumed *losses* (see also [rule 4.6.1](#) and [footnote 32](#)).

- 4.6.1 For the purposes of this methodology, a **loss (re-emission) pathway** is defined as any biogeochemical event or process in the environment following the initial CO₂ sequestration by the DACOS activity, which results or can reasonably be expected to result in a portion of the sequestered carbon being either released back to the atmosphere, or converted into a form in which the carbon can no longer be considered permanently stored.³²
- 4.6.2 The CO₂ Removal Supplier shall identify all loss (re-emission) pathways associated with the DACOS activity. The identified loss pathways shall at least include the secondary precipitation of calcium carbonate (CaCO₃).
- 4.6.3 The CO₂ Removal Supplier shall quantify the total greenhouse gas emissions due to the identified loss pathways (C_{loss}) as follows.

$$C_{\text{loss}} = \sum_{i \in S} m\text{CO}_2 e_i \quad (4.10)$$

Variable	Description	Unit
C_{loss}	Total losses of the sequestered CO ₂ as a result of subsequent chemical reactions in the environment following the initial carbon sequestration.	tCO ₂ e
$m\text{CO}_2 e_i$	Total mass of GHGs emitted from loss pathway i .	tCO ₂ e
i	Summation index (an element in the set of loss pathways S)	unitless
S	The set of relevant identified loss pathways (e.g. secondary precipitation, see rule 4.6.2).	unitless

- 4.6.4 The CO₂ Removal Supplier shall quantify the total amount of CO₂ released from each identified loss pathway ($m\text{CO}_2 e_i$, see [rule 4.6.3](#)) through measurement or conservative estimation as further detailed in [subrules a](#) and [b](#).
- For the pathway **secondary precipitation of calcium carbonate** (CaCO₃), the CO₂ Removal Supplier shall quantify the saturation index with respect to aragonite of the seawater discharge, and compare this value with the local threshold saturation index for calcium carbonate precipitation in the ambient seawater.³³

³² Note that this definition applies to re-emission pathways known or assumed *a priori*, and which therefore need to be accounted for at the time of CORC issuance. Previously unknown or unanticipated re-emissions after issuance of CORCs are termed *reversals* and are accounted for via a procedure described in the Puro Standard general rules.

³³ Note that the saturation index of aragonite varies across the ocean, as it is affected by a several processes in the marine environment, such as the organic production and degradation of organisms, water mass mixing, CaCO₃ production/dissolution, upwelling, river input and temperature changes (Sun et al., 2021). The value for aragonite saturation index in the local ambient seawater can be determined based on e.g. local measurements or values published in peer-reviewed scientific literature.

Where the saturation index of the seawater discharge exceeds the local threshold, the value of mCO_2e_i shall equal the amount of CO_2e stored in the $CaCO_3$ corresponding to this excess.

- b. For any other potential loss pathways identified in accordance with [rule 4.6.2](#) besides the one within the purview of [subrule a](#), the CO_2 Removal Supplier shall provide a detailed description of the identified pathway and the method of quantification.

4.7 Baseline removal ($C_{\text{baseline removal}}$)

For the DACOS activity, the relevant Baseline scenario that might contribute to the net carbon removal process is composed of two distinct pathways: the Baseline for ocean uptake of atmospheric carbon, and the Baseline for alkaline rock weathering (see [section 3.5](#)). However, because the outflowing seawater in the DACOS process has been re-equilibrated during the electrochemical processing, and therefore does not negatively affect the natural ocean uptake of CO_2 , the Baseline carbon removal corresponding to this term is set to zero in this methodology (see [rule 3.5.2a](#)).

- 4.7.1 The CO_2 Removal Supplier shall quantify the total amount of CO_2 that would have been stored (naturally or man-made) in the absence of the removal activity ($C_{\text{baseline removal}}$) as follows.

$$C_{\text{baseline removal}} = \underbrace{C_{\text{ocean}}}_{\text{set to 0}} + C_{\text{rock}} = C_{\text{rock}} \tag{4.11}$$

Variable	Description	Unit
$C_{\text{baseline removal}}$	Total amount of CO_2 that would have been stored (naturally or man-made) in the absence of the removal activity.	t CO_2e
C_{ocean}	Total amount of <i>additional</i> CO_2 sequestered in the Baseline scenario though natural ocean uptake compared to the DACOS activity. This term is set to 0 t CO_2 (see rule 3.5.2a) but is included here for completeness.	t CO_2e
C_{rock}	Total amount of CO_2 sequestered in the Baseline scenario through weathering of alkaline rock.	t CO_2e

- 4.7.2 The CO_2 Removal Supplier shall quantify the total amount of CO_2 sequestered (in t CO_2e) in the Baseline scenario through weathering of alkaline rock (C_{rock}) based on a scientifically justified estimate as further specified in [subrules a–f](#).

- a. The estimate shall be based on the state and physical properties of the alkaline rock or mineral feedstock as further described in [rule 4.7.3](#).

- b. The estimate shall be specific to the alkaline rock or mineral feedstock utilized by the CO₂ Removal Supplier.
- c. The estimate shall quantify the total amount of CO₂ sequestered over a weathering time period of 50 years following the commencement of the DACOS activity (C_{rock}).
- d. The CO₂ Removal Supplier shall to the best of their abilities estimate the likely fate and properties of the alkaline rock or mineral feedstock in the Baseline scenario, and utilize reasonable, conservative assumptions to account for variable or uncertain factors (such as the likely storage conditions over the estimation period).³⁴
- e. The estimate shall be conservative and be based on information gathered from either the CO₂ Removal Supplier's own scientific research or peer-reviewed scientific publications.
- f. The estimate shall contain a discussion of the assumptions utilized, as well as the level and sources of uncertainty in the amount of CO₂ sequestered.

4.7.3 The CO₂ Removal Supplier shall quantify the value of C_{rock} based on the state and physical properties (e.g. solid mineral, ground particles, or fine dust) of the feedstock material in the Baseline scenario,³⁵ as further specified in [subrules a](#) and [b](#).

- a. The quantification shall take into account the effect of at least the following factors to the sequestration rate:
 - (i) mineralogy,
 - (ii) physical form (including particle size),
 - (iii) reactive surface area, and
 - (iv) likely storage conditions.
- b. The quantification may utilize average sequestration rates from scientific literature, if such values are available and applicable to the external conditions under consideration. A full chemical kinetics simulation is not required.

³⁴ Although there are inherent uncertainties associated with e.g. unforeseen changes in storage conditions during the estimation period, the CO₂ Removal Supplier shall strive to account for such factors to the best of their ability.

³⁵ For example, projects aiming to utilize existing mine tailing storages must base the estimate on the type and size of particles typically found in such tailings.

- c. The quantification shall only consider the effect of natural CO₂ sequestration of the feedstock material, and shall not include deductions due to any potential avoided emissions compared to the Baseline case.³⁶

4.8 Summary of parameters

The following [Table 4.2](#) contains a summary of the parameters encountered in this section together with reference to the rule where they first occur.

Table 4.2. Summary of parameters utilized in this section.

Variable	Description	Unit	Reference
CORCs	Net amount of CO ₂ equivalents removed by the direct air capture and ocean storage activity.	tCO ₂ e	rule 4.2.1
C _{stored}	The gross amount of eligible CO ₂ stored in solid carbonates or dissolved bicarbonates. Further requirements on the calculation of this term are given in section 4.3 .	tCO ₂ e	rule 4.2.1
C _{loss}	Losses of CO ₂ removal due to degassing, precipitation, or other pathways. Further requirements on the calculation of this term are given in section 4.6 .	tCO ₂ e	rule 4.2.1
C _{baseline removal}	The total amount of CO ₂ that would have been stored (naturally or man-made) in the absence of the removal activity. Further requirements on the calculation of this term are given in section 4.7 .	tCO ₂ e	rule 4.2.1
E _{project}	Life cycle emissions arising from the whole supply chain of the direct air capture and ocean storage activity and allocated to the carbon removal project. Further requirements on the calculation of this term are given in section 4.4 .	tCO ₂ e	rule 4.2.1
E _{indirect}	Indirect GHG emissions due to unmitigated negative ecological, market, and activity-shifting leakage or indirect emissions resulting from the direct air capture and ocean storage activity. Further requirements on the calculation of this term are given in section 4.5 .	tCO ₂ e	rule 4.2.1
CO _{2,dissolved}	Total amount of carbon contained as dissolved inorganic species as a product of the DACOS activity.	tCO ₂ e	Rule 4.3.1
CO _{2,solid}	Total amount of carbon contained as solids species as a product of the direct air capture and ocean storage activity.	tCO ₂ e	Rule 4.3.1

³⁶ For example, if the feedstock material were transported from a mine to the project site via diesel truck, it is not permissible to deduct the transport CO₂ emissions from the Baseline sequestration amount on the basis that such emissions would not have occurred in the absence of the DACOS activities.

Variable	Description	Unit	Reference
ΔDIC	The difference in dissolved inorganic carbon between the seawater intake and discharge (i.e. the increase in DIC from Point A to Point E in Figure 7.2).	mol/L	Rule 4.3.2
CDR_{DIC}	The amount of CO ₂ removed per mol of DIC species (i.e. per mole of carbon contained in the various DIC species), $\text{CDR}_{\text{DIC}} = 1 \frac{\text{mol CO}_2\text{e}}{\text{mol C}}$	$\frac{\text{mol CO}_2\text{e}}{\text{mol C}}$	Rule 4.3.2
F_{avg}	The average liquid flow rate in a minute.	L/min	Rule 4.3.2
SI	Sampling interval.	min	Rule 4.3.2
M_{CO_2}	The molar mass of CO ₂ , $M_{\text{CO}_2} = 44.01 \frac{\text{g}}{\text{mol}}$.	g/mol	Rule 4.3.2
$\Delta\text{CO}_{2(\text{aq})}$	The calculated difference in dissolved CO ₂ between the seawater intake and discharge (i.e. from Point A to Point E in Figure 7.2).	mol / L	Rule 4.3.3
ΔHCO_3^-	The calculated difference in dissolved bicarbonate (HCO ₃ ⁻) between the seawater intake and discharge (i.e. from Point A to Point E in Figure 7.2).	mol / L	Rule 4.3.3
ΔCO_3^{2-}	The calculated difference in dissolved carbonate (CO ₃ ²⁻) between the seawater intake and discharge (i.e. from Point A to Point E in Figure 7.2).	mol / L	Rule 4.3.3
$\Delta\text{H}_2\text{CO}_3$	The calculated difference in dissolved carbonic acid (H ₂ CO ₃) between the seawater intake and discharge (i.e. from Point A to Point E in Figure 7.2). Note that due to its rapid dissociation, the concentration of H ₂ CO ₃ is usually very low compared to the other species.	mol / L	Rule 4.3.3
w_i	Mass fraction of the particular mineral phase <i>i</i> as obtained by XRD	%mass	Rule 4.3.4
R_i	The molar ratio of CO ₂ removed per mol of mineral produced (see Table 4.1)	mol/mol	Rule 4.3.4
m_{solids}	The total mass of solids produced as obtained by truck scale with a weighbridge	g	Rule 4.3.4
m_{water}	The total mass of water in the solids as measured by TGA	g	Rule 4.3.4
M_i	Molar mass of the particular mineral phase <i>i</i> (see Table 4.1)	g/mol	Rule 4.3.4
E_{total}	Total life cycle emissions arising from the whole supply chain of the direct air capture and ocean storage.	tCO ₂ e	Rule 4.4.2
E_{H_2}	Total life cycle emissions allocated to the production of low or zero carbon hydrogen. Further requirements on the calculation of this term are given in section 5.3 .	tCO ₂ e	Rule 4.4.2

Variable	Description	Unit	Reference
E_{ops}	Total operational emissions during the monitoring period, resulting from the DACOS activity across the whole supply chain. Further requirements on the calculation of this term are given in section 5.2 (see esp. rule 5.2.6).	tCO ₂ e	Rule 4.4.3
E_{emb}	Total embodied emissions allocated to the monitoring period, resulting from the DACOS activity across the whole supply chain. Further requirements on the calculation of this term are given in section 5.2 (see esp. rule 5.2.14). Note that for the purposes of CORC calculation, the embodied emissions are amortized according to rule 5.2.16 .	tCO ₂ e	Rule 4.4.3
E_{ECO}	Total GHG emissions due to unmitigated indirect ecological emissions resulting from the DACOS activity. Further requirements on the calculation of this term are given in section 6 .	tCO ₂ e	Rule 4.5.1
E_{MA}	Total GHG emissions due to unmitigated negative market and activity shifting resulting from the DACOS activity. Further requirements on the calculation of this term are given in section 6 .	tCO ₂ e	Rule 4.5.1
mCO_2e_i	Total mass of GHGs emitted from loss pathway i .	tCO ₂ e	Rule 4.6.1
C_{ocean}	Total amount of <i>additional</i> CO ₂ sequestered in the Baseline scenario though natural ocean uptake compared to the DACOS activity. This term is set to 0 tCO ₂ (see rule 3.5.2a) but is included here for completeness.	tCO ₂ e	Rule 4.7.1
C_{rock}	Total amount of CO ₂ sequestered in the Baseline scenario through weathering of alkaline rock.	tCO ₂ e	Rule 4.7.1

5 Determination of project emissions (E_{project})

5.1 General life cycle assessment requirements

- 5.1.1 The CO₂ Removal Supplier shall conduct a life cycle assessment (LCA) for the DACOS activity, which results in two co-products hydrogen and carbon removal. The LCA shall follow the general principles defined in ISO 14040/44 and the scope defined in [sections 4 and 5](#) of this methodology.
- 5.1.2 The LCA shall explain and justify the data and modeling choices made, as well as include all supporting calculation files which will be used in the calculation of CORCs.
- 5.1.3 The LCA shall calculate the climate change impact of the activity, characterized using the 100-year global warming potential (GWP₁₀₀) values from the most recent published assessment report of the Intergovernmental Panel on Climate Change (IPCC).³⁷ Other environmental impact categories may be included but are not required.
- 5.1.4 The emission factors used in the LCA shall at least include the contribution of major greenhouse gases (fossil CO₂, biogenic CO₂, CH₄, N₂O). The emission factors used in the LCA shall include a full scope of emissions (i.e. upstream and downstream emissions).³⁸
- 5.1.5 For transparency, interpretability and auditing purposes (i.e. verification of claims), the climate change impact calculated in the LCA shall be presented in a disaggregated way exhibiting the contributions of the different life cycle stages described in [Figure 5.1](#) and [Table 5.2](#), as well as the contributions of major greenhouse gases (i.e., CO₂, CH₄, N₂O) in tCO₂e and other greenhouse gases to this total climate impact. In case any of the contributions defined in [Figure 5.1](#) or [Table 5.2](#) are deemed to be null or irrelevant, the CO₂ Removal Supplier shall provide an explicit justification thereof in the LCA report and calculation files.

³⁷ At the time of writing (January 2025), the most recent published GWP₁₀₀ values are found in the IPCC Sixth Assessment Report (AR6), see Tables 7.15 and 7.SM.6 in Chapter 7 of the [IPCC AR6 Working Group 1 report](#) as well as section 7.2.1.5 in [Volume 1 on General Guidance and Reporting in the 2019 Refinement to the 2006 IPCC Guidelines](#).

³⁸ For example, in the case of transport related emission factors, these shall include so-called “well-to-wheels”, as opposed to only “well to tank” or “tank-to-wheels”.

- 5.1.6 If waste, recycled or secondary resources are used as input to the activity (e.g., waste rock,³⁹ recycled steel), it is permissible and recommended to apply the cut-off approach⁴⁰ for waste, recycled and secondary products in the LCA. Specifically, the environmental burdens from the production of secondary resources may be excluded from the system boundary, but the supply, transformation and handling of secondary resources must be included.
- 5.1.7 If co-products *with a meaningful use outside the system boundary* are generated during the activity, an allocation of the relevant life cycle stages between the co-products may be applied (see [section 5.3](#)). The CO₂ Removal Supplier shall select an allocation procedure among the following options:
- a. Allocation based on the stepwise process described under ISO 14044:2006, starting by determining the physical relationship as the basis for the allocation.
 - b. Allocation based on the economic value or statutory requirements of the products, where applicable (e.g. based on the US Inflation Reduction Act of 2022, Section 45V).⁴¹
- 5.1.8 The CO₂ Removal Supplier shall coordinate data collection and LCA modeling with any external operators to the level necessary to ensure compliance with this methodology and the Puro Standard requirements.
- 5.1.9 The CO₂ Removal Supplier shall specify and account for project emissions in the LCA under two categories, operational and embodied emissions, as further specified in [subrules a](#) and [b](#).
- a. **Operational emissions** of facilities or other types of infrastructure and machinery include the energy used to operate these assets and the material inputs necessary for their operation (e.g. alkaline rock, GAC, etc.).⁴² These emissions result from the project activities during the monitoring period and shall be subtracted from the gross carbon captured during the same period.

³⁹ For example, rock dust—often considered a byproduct of quarries or mines—can potentially be classified as a waste material due to its limited direct applications. Substantial amounts of rock dust are generated during extraction of rocks for various purposes, such as during construction or mining operations.

⁴⁰ Description of the cut-off system model is available on the website of the [ecoinvent life cycle database](#). Under the cut-off approach “recyclable materials are available burden-free to recycling processes, and secondary (recycled) materials bear only the impacts of the recycling processes”

⁴¹ See United States Department of the Treasury and Internal Revenue Service document 90 FR 2224, [Credit for Production of Clean Hydrogen and Energy Credit](#) (January 2025). Also published under 26 CFR Part 1 - Rules for Computing Credit for Investment in Certain Depreciable Property (Jan. 15, 2025), §§ 1.45V-1 through 1.45V-6 ([26 CFR 1.45V](#)).

⁴² Note that the additional energy demand caused by the DACOS activity might necessitate a further quantification and accounting of the indirect emissions (i.e. market leakage) related to the additional electricity demand (see [section 6](#)).

- b. **Embodied emissions** of infrastructure and/or equipment represent the carbon emitted in the fabrication, construction, maintenance, and demolition of these assets, and in the land-use conversion associated with the production facility and supporting infrastructure (when applicable).

5.2 Methodology-specific life cycle assessment

System boundary and unit processes

Figure 5.1 depicts the system boundary applicable to this methodology (see rule 5.2.1), and Table 5.1 includes a summary of the various carbon pools (emission sources, carbon sinks, and carbon reservoirs) relevant to this methodology.

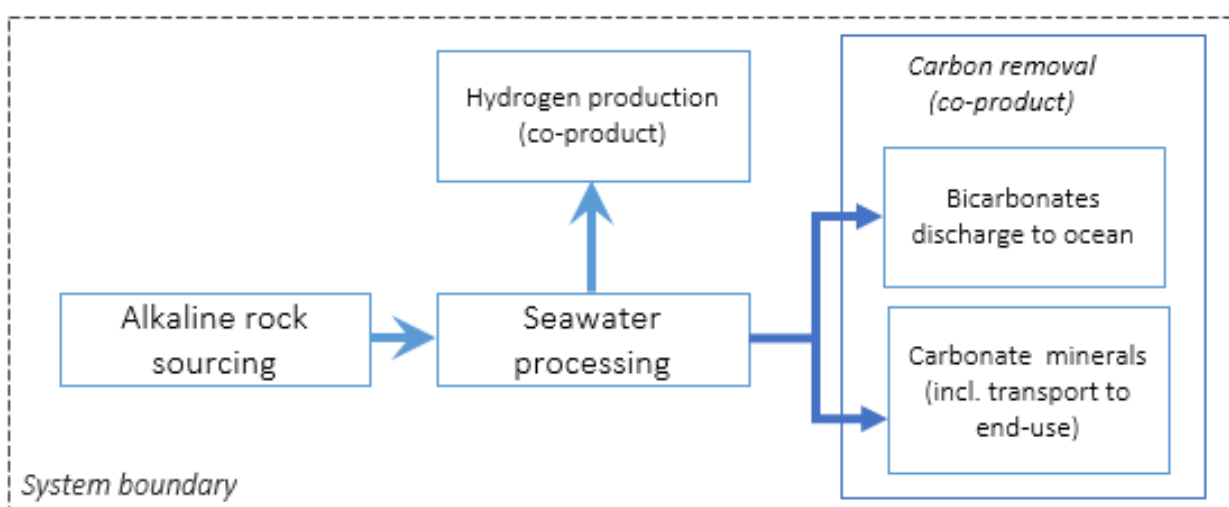

Figure 5.1. System boundary and unit processes of DACOS activity for GHG accounting

Table 5.1 Greenhouse gas sources, sinks and reservoirs (GHG SSR) within the system boundary

Process stage	GHG SSR ⁴³	Relevant GHGs
Operating and maintaining the electrolyzer and balance of the plant	Source	CO ₂ , N ₂ O, CH ₄
Grinding rock (e.g. milling if applicable)	Source	CO ₂ , N ₂ O, CH ₄
Transporting ground rock to the facility	Source	CO ₂ , N ₂ O
Building CDR plant	Source	CO ₂ , N ₂ O, CH ₄
Absorbent for gases to meet regulatory requirements, if required	Source	CO ₂ , N ₂ O, CH ₄

⁴³ ISO 14064-2:2019 Greenhouse gases, Part 2: Specification with guidance at the project level for quantification, monitoring and reporting of greenhouse gas emissions reductions or removal enhancements.

Process stage	GHG SSR ⁴³	Relevant GHGs
Dissolved carbonates and bicarbonates in seawater discharge	Sink	CO ₂
Carbonate solid disposal on land	Sink	CO ₂
Pool of carbonates and bicarbonates in seawater	Reservoir	CO ₂

- 5.2.1 The **system boundary** in the DACOS process shall encompass two co-products with significant economic value: 1) carbon removal, and 2) hydrogen. These co-products represent two distinct functional units for the purpose of LCA calculations.
- 5.2.2 The CO₂ Removal Supplier shall utilize the **functional units** of LCA defined in [subrules a and b](#).
- a. For the carbon removal co-product, the functional unit of LCA shall be *1 metric tonne of carbon dioxide removed and contained in bicarbonates discharged in the ocean and as solid carbonates*.
 - b. For the hydrogen co-product, the functional unit of LCA shall be *1 kg of hydrogen produced from the electrolysis process*.
- 5.2.3 The CO₂ Removal Supplier shall define the **spatial boundaries** of the LCA, including at least:
- the location of the production facility and any other relevant industrial sites or facilities (e.g. the storage site for disposed mineral carbonates),
 - the transport routes necessary for the operations of the production facility,
 - the areas from which the alkaline rock is sourced,
 - the area from which electricity is produced, and
 - the areas of seawater intake and discharge.
- 5.2.4 The CO₂ Removal Supplier shall define the **time boundaries** of the LCA, including at least the planned duration of the carbon capture and storage activities, and the planned lifetime of key infrastructure (e.g. facilities, pipelines). The CO₂ Removal Supplier shall disclose in the LCA both technical design lifetimes, as well as any useful lifetimes, as useful lifetimes may be shorter than technical design lifetimes. To the extent that those lifetimes are less than 15 years, it may affect how embodied emissions are amortized (see [rules 5.2.15 and 5.2.16](#)).

5.2.5 The CO₂ Removal Supplier shall prepare the LCA in accordance with the **system boundary** and the **unit processes** defined in [Figure 5.1](#) and [subrules a-e](#). The LCA report shall include a project-specific process-flow diagram detailing each of these unit processes.⁴⁴

- a. The unit process **alkaline rock sourcing** (E_{rock}) refers to the GHG emissions associated with all activities required for the sourcing and processing of this material. The GHG emissions associated with alkaline rock sourcing can be summarized as follows:
 - *Operational emissions* include emissions related to transportation of alkaline rock from mining site, and pre-processing for use by grinding/milling (if necessary).
 - *Embodied emissions* include emissions related to the infrastructure for the grinding/milling and other processing of alkaline rock.
- b. The unit process **seawater processing** ($E_{\text{electricity}}, E_{\text{GAC}}$) refers to the GHG emissions associated with construction, maintenance, and disposal of equipment required for the sourcing, processing and discharge of seawater and bicarbonates, as well as the energy required for the electrochemical processing. The GHG emissions associated with seawater processing can be summarized as follows:
 - *Operational emissions* include emissions related to the energy used by the different electrochemical and balance of plant processes used in the carbon capture.
 - *Embodied emissions* include emissions related to the construction, maintenance and disposal of any equipment (e.g. pipeline, equipment, building facility) needed for the sourcing, processing, and disposal of seawater and bicarbonates of the DACOS process.
- c. The unit process **bicarbonates discharge to the ocean** and the emissions associated therein are treated as part of the unit process **seawater processing** (see [subrule b](#)).
- d. The unit process **carbonate minerals (incl. transport to end use)** (E_{disposal}) refers to GHG emissions associated with the disposal of carbonates into an end-use with durable storage. The GHG emissions associated with carbonate minerals (incl. transport to end use) can be summarized as follows:
 - *Operational emissions* include emissions related to transporting carbonated rock to a disposal site.

⁴⁴ The unit processes define the scope and completeness of life cycle inventories, see also [rule 5.4.1](#).

- *Embodied emissions* are included as part of the DACOS plant.
- e. The unit process **hydrogen production** (E_{H_2}) refers to GHG emissions associated with the post-production processing of the hydrogen produced during the electrochemical processing step.⁴⁵ The CO₂ Removal Supplier shall allocate a portion of the total project emissions to the hydrogen production step according to the requirements in [section 5.3](#).

Operational emissions

5.2.6 The CO₂ Removal Supplier shall determine the total operational emissions arising from the DACOS activity (E_{ops}) as follows:

$$E_{ops} = E_{rock} + E_{electricity} + E_{GAC} + E_{disposal} + E_{H_2released} \tag{5.1}$$

Variable	Description	Unit
E_{ops}	Total operational emissions arising from the DACOS activity across the whole supply chain.	tCO ₂ e
E_{rock}	Total life cycle emissions arising from sourcing alkaline rock, including grinding and transportation (see rule 5.2.7).	tCO ₂ e
$E_{electricity}$	Total life cycle emissions arising from the electricity consumption during the operation of the plant (see rule 5.2.8).	tCO ₂ e
E_{GAC}	Total life cycle emissions arising from the use of Granular Activated Carbon (GAC) (see rule 5.2.9).	tCO ₂ e
$E_{disposal}$	Total life cycle emissions arising from the disposal of solid carbonate minerals, including transportation (see rule 5.2.10).	tCO ₂ e
$E_{H_2released}$	Total GHG emissions associated with any hydrogen released to the atmosphere due to the DACOS activity during the monitoring period (see rule 5.2.11).	tCO ₂ e

5.2.7 The CO₂ Removal Supplier shall quantify the total life cycle emissions arising from sourcing alkaline rock, including grinding and transportation (E_{rock}) as follows:

$$E_{rock} = E_{mining} + E_{grind} + E_{transp} \tag{5.2}$$

- a. In cases where the alkaline rock utilized is mined or produced for the specific purpose of the DACOS activity, the CO₂ Removal Supplier shall quantify the total operational GHG emissions associated with the mining or production of rock (E_{mining}).

⁴⁵ Note that both the carbon removal and the hydrogen co-products generated during the DACOS activity are an undivided part of the main electrochemical process.

- (i) In cases where the alkaline rock is a waste product (e.g. mine tailings or similar wastes), its life cycle emissions may be omitted from this calculation, and the CO₂ Removal Supplier may utilize the value $E_{\text{mining}} = 0 \text{ tCO}_2\text{e}$ (see also [rule 5.1.6](#)).
- b. The CO₂ Removal Supplier shall quantify the total GHG emissions from the transport of the alkaline rock (E_{transp}) as follows:

$$E_{\text{transp}} = 2d \times EF_{\text{transport}} \tag{5.3}$$

- (i) For quantification of operational emissions related to the transportation of alkaline rock to the electrochemical processing facility, the transportation distance to the project site shall be aggregated on a mass-averaged distance.
- (ii) The CO₂ Removal Supplier shall utilize an aggregated region-specific emissions factor for the given mode of transportation.
- c. In cases where the sourced alkaline rock requires *additional* grinding (mineral comminution) to meet the anolyte process requirements, the CO₂ Removal Supplier shall quantify the total GHG emissions associated with the grinding (comminution) process as follows:⁴⁶

$$E_{\text{grind}} = 10 \times W_i \times \underbrace{\left(\frac{1}{\sqrt{P_{80}}} - \frac{1}{\sqrt{F_{80}}} \right)}_{\text{Energy required for grinding}} \times m_{\text{grind}} \times EF_{\text{grind}} \tag{5.4}$$

- (i) In cases where the alkaline rock utilized by the CO₂ Removal Supplier utilizes is a waste product that does not require additional grinding to meet the anolyte process requirements, the CO₂ Removal Supplier may utilize the value $E_{\text{grind}} = 0 \text{ tCO}_2\text{e}$ (see also [rule 5.1.6](#)).
- (ii) The operating work index (W_i) shall be calculated monthly. In addition, plant performance shall be benchmarked against the calculation of a grindability measurement made in a laboratory work index apparatus, such as a ball mill work index or rod mill work index.

Variable	Description	Unit
E_{mining}	Total GHG operational emissions associated with the mining or production of alkaline rock	tCO ₂ e

⁴⁶ The energy required for grinding is derived from Bond’s law, which states that states that the work required to from particles of size is proportional to the square root of the volume ratio of the product (Bond, 1961).

Variable	Description	Unit
E_{grind}	Total GHG emissions associated with the grinding (comminution) process	tCO ₂ e
E_{transp}	Total GHG emissions from the transport of the alkaline rock from its sourcing site (e.g. mine) to the DACOS facility	tCO ₂ e
d	The average distance between the DACOS facility and the rock quarry	km
$EF_{\text{transport}}$	The emission factor for the mode of transport utilized, as adjusted for a round-trip load	tCO ₂ e/km
W_i	The operating work index for grinding for the utilized feedstock, calculated monthly from the kWh power consumption and actual tonnes milled.	kWh/t
P_{80}	The particle sizes corresponding to 80% of passings of sample feed	μm
F_{80}	The particle sizes corresponding to 80% of passings of the product feed.	μm
m_{grind}	Mass of rock processed during grinding.	t
EF_{grind}	Emission factor of the energy used in the grinding (comminution) process.	tCO ₂ /kWh

5.2.8 The CO₂ Removal Supplier shall quantify the total GHG emissions resulting from the electricity consumed by operating the electrochemical processing facility ($E_{\text{electricity}}$) as follows:

$$E_{\text{electricity}} = Q_{\text{electricity}} \times EF_{\text{electricity}} \quad (5.5)$$

Variable	Description	Unit
$E_{\text{electricity}}$	Emissions from the total power consumption metered across the whole plant including electrolyzer, H ₂ compressors, pumps, blowers, and any auxiliary sources.	tCO ₂ e
$Q_{\text{electricity}}$	Amount of electricity consumed during the monitoring period.	MWh
$EF_{\text{electricity}}$	The average GHGs emitted per unit of electricity generated within the grid and differs depending on the country and source of power. See rule 5.2.13 for further details on the determination of this variable.	tCO ₂ e/MWh

5.2.9 The CO₂ Removal Supplier shall determine the total GHG emissions associated with the use of granular activated carbon (E_{GAC}) as follows.⁴⁷

$$E_{GAC} = Q_{GAC} \times EF_{GAC} \tag{5.6}$$

Variable	Description	Unit
E_{GAC}	Total GHG emissions associated with the use of granular activated carbon.	tCO ₂ e
Q_{GAC}	The quantity of GAC used during the monitoring period.	t
EF_{GAC}	The lifecycle emission factor of the GAC utilized in the DACOS activity.	tCO ₂ e/t

5.2.10 The CO₂ Removal Supplier shall determine the total GHG emissions associated with the disposal of carbonates into an end-use with durable storage ($E_{disposal}$) as follows:

$$E_{disposal} = 2 \times d_{disposal} \times EF_{disposal} \tag{5.7}$$

Variable	Description	Unit
$E_{disposal}$	Total GHG emissions associated with the disposal of carbonates into an end-use with durable storage	tCO ₂ e
$d_{disposal}$	The average distance between the electrochemical processing facility and the disposal site.	km
$EF_{disposal}$	The emission factor of the transport mode.	tCO ₂ e/km

5.2.11 The CO₂ Removal Supplier shall quantify and account for any hydrogen released to the atmosphere due to the DACOS activity ($E_{H_2 \text{ released}}$).⁴⁸ The CO₂ Removal Supplier shall treat any hydrogen unaccounted for by metering as having been released to the atmosphere, and determine the amount of hydrogen released from the containment through mass balance. Hydrogen released to the atmosphere shall be assumed to have a GWP of 14.4 gCO₂e/MJ (Sand et al., 2023).

5.2.12 The CO₂ Removal Supplier shall collect and organize the elements and processes that contribute to generate operational emissions (E_{ops}) according to the levels of information described in [Table 5.2](#) and in [subrules a](#) and [b](#).

⁴⁷ During the electrochemical processing of seawater, a small amount of chlorine gas is produced due to the selectivity of oxygen during reactions in the anode. To mitigate the release of chlorine gas, a small amount of granular activated carbon (GAC) can be utilized to chemically scrub the anode which has the potential to produce a limited amount of CO₂.

⁴⁸ The co-produced hydrogen is intended to be captured and contained on-site, but might be inadvertently be released to the atmosphere during project operations. Although hydrogen is not a greenhouse gas, it has an impact in global warming through its chemical reactions.

- a. The LCA results must be provided in a disaggregated manner aligned with Table 5.2, exhibiting the contributions of each main stage (level 1) and substage (level 2). Each sub-stage can be further divided into contributions (level 3) relevant for each project type. If a contribution is deemed not relevant or equal to 0, an explicit motivation shall be provided (see rule 5.1.5).
- b. The CO₂ Removal Supplier shall publicly disclose in the Puro Registry, as part of annual Output Audit, at least the contributions marked with an asterisk (*) in Table 5.2.

Table 5.2. Summary of operational lifecycle emissions of the DACOS activity (see rule 5.2.12).

Main stages Level 1 contributions	Sub-stages Level 2 contributions	Further sub-stages Level 3 contributions
*E _{rock}	*Operational emissions of material input sourcing.	Energy use for transport and/or grinding (e.g., heat, electricity, fuel). Lifecycle emission factor (if applicable)
*E _{GAC}	*Operational emissions of carbon capture processes	Quantity of GAC use during monitoring period Emission factor of GAC
*E _{electricity}	*Operational emissions from electricity use to operate the DACOS plant	Quantity of electricity Emission factor of electricity
*E _{disposal}	*Operational emissions of the disposal of carbonates	Quantity of carbonates Disposal transport distance Emission factor of transport mode
E _{H₂released}		

* The contributions marked with an asterisk (*) must be publicly disclosed in the Puro Registry as part of annual Output Audit (see rule 5.2.12b).

- 5.2.13 Whenever external energy inputs are used along the supply chain, e.g., electricity from the grid or steam/heat from a local network, the CO₂ Removal Supplier may utilize renewable energy certificates (REC), guarantees of origin (GOO), direct purchase agreements (DPA), and similar renewable low-carbon energy supply schemes, and thereby correspondingly adjust the emission factors used in the LCA, provided that *all of the requirements* in [subrules a–f](#) are fulfilled:
- a. The purchased certificates originate from the same physical grid or network as where they are consumed (i.e. same spatial resolution). For example, in the United States, this means that electricity must be delivered from the regions defined under the National Transmission Needs Study (DOE, 2023).
 - b. The purchased certificates have been issued within the same calendar year as when they are consumed (i.e. same temporal resolution) for electricity generated prior to January 1st, 2028. After this date, the temporal matching of the consumed electricity and its emission factor must be reported hourly when such information is available.⁴⁹
 - c. The purchased certificates specify the energy source or mix of sources, so that a climate change footprint can be calculated and used in the LCA (i.e. non-zero value).
 - d. The purchased certificates specify when the production capacity of the energy source or mix of sources was commissioned. That information is then disclosed by the CO₂ Removal Supplier as part of the Output Audit. The information on the year of commissioning of the energy asset indicates the additionality of the renewable energy production, allowing to distinguish between already existing assets and more recently built assets.
 - e. The amount of purchased certificates matches with the amounts of low-carbon energy declared in the LCA calculations.
 - f. The CO₂ Removal Supplier provides evidence of purchased certificates at each Output Audit, or alternatively reverts to using market average emission factors if certificates are no longer purchased.

Embodied emissions

- 5.2.14 The CO₂ Removal Supplier shall determine the total embodied emissions ($E_{\text{total emb}}$) associated with the materials and processes used to build, maintain, and dispose of the DACOS facility over the lifetime of the project as further specified in [subrules a-g](#).

⁴⁹ See also United States Department of the Treasury and Internal Revenue Service document 90 FR 2224, [Credit for Production of Clean Hydrogen and Energy Credit](#) (January 2025).

- a. The CO₂ Removal Supplier shall quantify the total embodied emissions ($E_{\text{total emb}}$) as follows

$$E_{\text{total emb}} = \sum_{i \in S} Q_i \times EF_i \tag{5.8}$$

Variable	Description	Unit
$E_{\text{total emb}}$	Total embodied emissions arising from the DACOS activity over its entire lifetime	tCO ₂ e
Q_i	Quantity of the resource i utilized over the amortized lifetime of the DACOS facility	[unit] ^a
EF_i	Emission factor for the resource i	tCO ₂ e/[unit] ^a
i	Summation index (an element in the set of resources S)	unitless
S	The set of resources utilized (e.g. concrete, steel, fuel, etc.)	unitless

^a Note that [unit] refers to an appropriate unit depending on the resource, such as tonne, or MJ.

- b. The calculation of embodied emissions shall include at least the following elements:
- Production of key materials (concrete, asphalt, steel).
 - Transport of key materials to site.
 - Energy usage during construction (fuels, electricity).
 - Disposal of waste arising during construction (e.g. excavated material sent for disposal).
 - Disposal of key materials at end-of-life (e.g. using default processes available in LCA databases for disposal).

For the process-based LCA calculation of whole building and infrastructure projects, the following standards are referenced as general guidance: EN 15804+A2,⁵⁰ EN 15978,⁵¹ and ISO 21930:2017.⁵²

⁵⁰ EN 15804:2012+A2:2020 Sustainability of construction works - Environmental product declarations - Core rules for the product category of construction products.

⁵¹ EN 15978:2012 Sustainability of construction works - Assessment of environmental performance of buildings - Calculation method.

⁵² ISO 21930:2017 Sustainability in buildings and civil engineering works - Core rules for environmental product declarations of construction products and services.

- c. The CO₂ Removal Supplier may utilize recent monetary emission factors (e.g. kg CO_{2e} per USD spent) to estimate embodied emissions based on capital expenditure (CAPEX), provided that such factors are available in the countries where the facilities are built.⁵³
- d. Embodied emissions shall account for the *land-use conversion* if land use has been changed for the construction of the site e.g., from agriculture or forest land to an industrial site.
- e. The embodied emissions of pre-existing facilities shall not be accounted for in the project's emissions. However, additional embodied emissions associated with retrofitting and maintaining the retrofitted facilities shall be accounted for.

For shared facilities, the embodied emissions shall, whenever possible, be allocated to the participating users based on the stepwise process described under ISO 14044:2006, starting by determining the physical relationship as the basis for the allocation. If that is not possible, then the allocation based on statutory requirements, or the economic value of the products shall be used.

- f. The embodied emissions of alkaline rock sourcing shall not be accounted for in the project's emissions provided that the alkaline rock is waste material and that the infrastructure necessary to process the material forms part of an existing mining, quarrying, or similar operation (see [rule 5.1.6](#)).
- g. Embodied emissions shall be calculated and amortized against the gross carbon captured according to the rules described in [rules 5.2.15](#) and [5.2.16](#).

5.2.15 In the context of this methodology, the **amortization of the embodied emissions** of an asset (infrastructure or equipment) is the process of apportioning the embodied emissions associated with the production, maintenance, and decommissioning of the asset in line with its expected operational life or the project's lifetime assumption.

- a. The amortization period of the embodied carbon shall be equal to the length of the first Crediting Period (15 years, see [rule 2.2.2](#)), or the lifetime assumption of the asset if it is shorter than the Crediting Period. This period starts with the first date of the first monitoring period.
- b. After the first 15 years, recurring maintenance-related emissions shall be amortized annually, if they exceed the cut-off value in [rule 5.4.1](#). In case the facility or transport infrastructure is shared with other operators outside the project boundaries, the embodied emissions shall be allocated based on the share of operation or use calculated annually within the 15-year period.

⁵³ Such monetary emission factors are in general more conservative.

- c. If unplanned maintenance or infrastructure changes are necessary for the proper operation of the facility/infrastructure, the additional accrued carbon emissions shall be added to the embodied emissions and amortized accordingly.

5.2.16 The CO₂ Removal Supplier shall determine the embodied emissions allocated to the monitoring period (E_{emb}) based on an amortization of the overall embodied emissions over the entire prescribed lifetime of the DACOS facility ($E_{total\ emb}$) in accordance with [rule 5.2.15](#) and as further defined in [subrules a-d](#).

- a. The CO₂ Removal Supplier shall utilize as the basis of the amortization an estimation of the total embodied emissions over the entire prescribed 15-year lifetime of the DACOS facility ($E_{total\ emb}$), quantified according to [rule 5.2.14](#).
- b. The annual amortized embodied emissions shall be determined by dividing the total embodied emissions ($E_{total\ emb}$) equally over the duration of the amortization period.

5.3 Emissions allocation to co-products

The DACOS process results in two co-products with economic value: 1) carbon removal, and 2) hydrogen (H₂). The co-products generated during the activity are an undivided part of the main electrochemical process. This subsection details how the project emissions are allocated to the co-products.

5.3.1 The CO₂ Removal Supplier shall allocate a portion of the total emissions of the DACOS activity (E_{total} , see also [rules 4.4.2](#) and [4.4.3](#)) to the hydrogen co-product (E_{H_2}) based on the mass of hydrogen generated during the monitoring period (m_{H_2}) in kg, and the economic relationship and **carbon intensity** (CI) of instruments such as tax credits, contract for difference, clean/low-carbon energy standard, or grant subsidies, as they apply to the co-products, and allowed under clause 4.3.4.2 of the ISO-14044 standard.⁵⁴ The CO₂ Removal Supplier shall quantify the emissions allocated to the hydrogen co-product as follows.

$$E_{H_2} = m_{H_2} \times CI \tag{5.9}$$

Variable	Description	Unit
E_{H_2}	Total life cycle emissions allocated to the production of low carbon hydrogen.	tCO ₂ e
m_{H_2}	Mass of hydrogen produced over the monitoring period.	kg
CI	The carbon intensity of the produced hydrogen.	tCO ₂ e/kg

⁵⁴ ISO 14044:2006 Environmental management — Life cycle assessment — Requirements and guidelines

EXAMPLE: According to [rule 5.3.1](#), the allocation of emissions to the hydrogen co-product (E_{H_2}) is determined based on the carbon intensity (CI) of the selected economic instrument. For example, in the United States, the federal regulations under Section 45V regarding the production of clean hydrogen define the carbon intensity of hydrogen production based on brackets (see [Table 5.3](#)) corresponding to the different tiers of the section 45V credit amount.⁵⁵

Table 5.3. Brackets for the carbon intensity of H₂ production as defined in Section 45V.^a

Carbon Intensity of H ₂ production
<0.44 kgCO ₂ e per kg of H ₂
0.45 to 1.49 kgCO ₂ e per kg of H ₂
1.50 to 2.49 kgCO ₂ e per kg of H ₂
2.50 to 4.00 kgCO ₂ e per kg of H ₂

^aSee [26 CFR 1.45V-1\(a\)\(3\)](#)

Assume that during a reporting period, 5000 kg of hydrogen of carbon intensity 0.44 kgCO₂e per kgH₂ is produced, and the total emissions in that period are 100 tCO₂e. $E_{total} = 100 \text{ tCO}_2\text{e}$, and the carbon intensity is $CI = 0.44 \text{ kgCO}_2\text{e/kg}$. Now

$$m_{H_2} = 5\,000 \text{ kg}$$

$$CI = 0.44 \text{ kgCO}_2\text{e/kg}$$

$$E_{total} = 100 \text{ tCO}_2\text{e},$$

and the allocation of emissions between hydrogen production (E_{H_2}) and project emissions ($E_{project}$) for the period is

$$E_{H_2} = m_{H_2} \times CI = 5000 \text{ kg} \times 0.44 \text{ kgCO}_2\text{e/kg} = 2\,200 \text{ kgCO}_2\text{e} = \underline{2.2 \text{ tCO}_2\text{e}}$$

$$E_{project} = E_{total} - E_{H_2} = 100 \text{ tCO}_2\text{e} - 2.2 \text{ tCO}_2\text{e} = \underline{97.8 \text{ tCO}_2\text{e}}.$$

5.4 Cut-off criteria

5.4.1 The CO₂ Removal Supplier shall endeavor to record in the lifecycle inventory (LCI) model approximately 100% of the project emissions. However, as the total inventory cannot be known with complete certainty, it is possible to exclude elements via the following cut-off criteria:

⁵⁵Further examples of these type of instruments are the IRA Provisions for Clean Hydrogen Production and Investment, or the certification of low carbon hydrogen production by “CERTIFHy” which sets a threshold value for low-carbon hydrogen at 36.4 gCO₂/MJ (4.4 kgCO₂ per kg H₂). For a summary of the planned certification systems and regulatory frameworks, see (IEA, 2024), [Table: Overview of existing and planned certification systems and regulatory frameworks](#).

- a. After a preliminary inventory model that aimed, under best judgment, to approximate 100% of the project emissions, the CO₂ Removal Supplier shall develop a unit process data set of at least 95% completeness for both embodied and operational emissions per activity boundary.
- b. The resulting flows or activities that individually represent less than 0.5% of the total approximated emissions of the corresponding activity boundary contained within the 5% cut-off value can be considered negligible and do not need to be included in the final project emissions calculations.
- c. The cut-off criteria shall be applied consistently to each activity boundary and separately for embodied and operational emissions.

5.4.2 The following elements are deemed not relevant for the purposes of LCA modelling and therefore do not need to be included therein:

- a. Site selection and feasibility studies
- b. Monitoring equipment embodies emissions
- c. Staff transport (e.g., business travel and employee commuting)

6 Determination of indirect emissions (leakage)

6.1 Overview

As defined in the Puro Standard General Rules (section 6.2), leakage refers to indirect emissions associated with the removal activity that may lead to an increase or decrease in greenhouse gas emissions or removals outside of the system boundaries of the activity. Conservatively, only the *increase in GHG emissions* or *decreases in carbon stocks* are quantified, and the removal activity is penalized if those effects are not avoided or mitigated. Net positive effects may also occur (decrease in emissions or increase in carbon uptake/stocks), but those are not included in the quantification of CORCs. In this methodology, the term “indirect emissions” (E_{indirect}) is utilized in place of “leakage” (see also Figure 4.1) to avoid confusion with any physical leaks, such as water or gas leaks.

For the purposes of this methodology, indirect emissions comprise unmitigated negative leakage due to either ecological leakage, or market and activity shifting resulting from the DACOS activity ($E_{\text{indirect}} = E_{\text{ECO}} + E_{\text{MA}}$, see rule 4.5.1). This section defines which sources of indirect emissions are relevant to consider for DACOS projects following the three-step approach defined in the Puro Standard General Rules:

1. Identify and characterize indirect emission sources.
2. Mitigate indirect emission sources.
3. Quantify unmitigated indirect emission sources.

6.2 Identification and characterization of indirect emission sources

6.2.1 For the purposes of this methodology, the terms *ecological indirect emissions* and *ecological leakage* (E_{ECO}) refer to negative effects on nearby land and ecosystems due to changes in land cover and land use for construction purposes because of the DACOS project. For example, such negative effects might include deforestation due to onshore construction or impacts on coral reefs due to building pipelines in the seabed.

6.2.2 For the purposes of this methodology, the terms *market activity indirect emissions* and *market activity leakage* (E_{MA}) refer to GHG emissions resulting from the DACOS project activities changing the supply/demand equilibrium, or displacing a previous activity outside the project’s boundaries, causing increased emissions elsewhere. For example, such changes in the supply/demand equilibrium might include changes in demand of renewable and low-carbon energy.⁵⁶ In this methodology, market and activity shifting leakage is further divided into the following subcategories:

⁵⁶ As the electrochemical processing of seawater is an energy intensive process, the availability of renewable and low-carbon energy is an important factor for DACOS. Therefore, DACOS projects can potentially lead to market and activity shifting leakage relating to renewable energy markets.

- Market and activity shifting indirect emissions relating to the use of renewable electricity when electricity is **from a grid**.
- Market and activity shifting indirect emissions relating to the use of renewable electricity when electricity is from an **off-grid source** already in use for other productive purposes.

6.3 Mitigation of indirect emission sources

6.3.1 The CO₂ Removal Supplier shall assess all sources of leakage identified in this methodology. Each leakage source must either be mitigated by fulfilling the rules in [section 6.3](#) or quantified as per the rules in [section 6.4](#).

6.3.2 For the purposes of this methodology, the identified sources of leakage are:

- a. Ecological leakage relating to negative effects on the nearby land and ecosystems surrounding the areas where facilities (electrochemical processing, logistics, storage facilities) are built or extended via land drainage or land cover change.
- b. Market and activity shifting leakage relating to the use of renewable electricity, when electricity is from a grid.
- c. Market and activity shifting leakage relating to the use of renewable electricity for the electrochemical processing, when electricity is from an off-grid source already in use for other productive purposes.

Further, it is considered that increased use of e.g. chemicals and other materials utilized in the DACOS process is not a relevant leakage source, as the emissions related to their production are included in the supply-chain emissions, assuming new production and the capacity to increase production of said materials (non-constrained market).

6.3.3 The CO₂ Removal Supplier shall assess and mitigate *ecological leakage, relating to negative effects on the nearby land and ecosystems surrounding the areas where facilities are built or extended* in accordance with the procedure further detailed in [subrules a-f](#).

- a. This leakage source shall be evaluated by the CO₂ Removal Supplier during the design phase of the project as part of an environmental impact assessment (EIA) study or in a standalone assessment. A retrospective assessment shall be performed for facilities that have been designed or built before the publication date of this methodology.
- b. The following high-level guidance is provided for conducting such an assessment. The assessment shall:
 - (i) Define the areas of land and ecosystems potentially affected (e.g. spatial extent, locations, soil types, hydrology, land cover, cultural and biodiversity values).

(ii) Determine whether the planned construction works will affect the local **hydrology**.

(iii) Determine whether the planned construction works will affect the **land cover**.

(iv) Conclude whether the nearby land and ecosystems will suffer from loss of carbon stocks or emissions of other greenhouse gases.

- c. If the assessment concludes that nearby land and ecosystems would *not be negatively affected*, this leakage source is considered mitigated and can be set to zero in the quantification.
- d. If the assessment concludes that nearby land and ecosystems *would be negatively affected*, the project shall perform an *ex-ante* quantification of the loss of carbon stocks and emission of greenhouse gases, which must then be included in the CORC quantification as per [rule 4.5.1](#). The *ex-ante* quantification shall be based on either site-specific quantification approaches, or methods derived from the IPCC Guidelines for National Greenhouse Gas Inventories using either the default values for land conversion available in the IPCC Guidelines for National Greenhouse Gas Inventories (IPCC, 2006, 2019) (Tier 1), or country-specific values (Tier 2), or data specific to the project (Tier 3).
- e. In case the assessment concluded that nearby land and ecosystems would be negatively affected, but that quantification is not possible, the project is then not eligible in its current design. However, construction plans or locations may be changed for the project to become eligible.
- f. In case the assessment concluded that nearby land and ecosystems would not be negatively affected, but later events and/or grievances demonstrate otherwise, penalties will apply retrospectively, following the Puro Standard General Rules for reversals.

6.3.4 In cases when the CO₂ Removal Supplier utilizes electricity is from a grid or from an off-grid source already in-use for other productive purposes, the CO₂ Removal Supplier shall assess and mitigate *market and activity shifting leakage relating to the utilization of renewable electricity* due to the DACOS activity in accordance with the procedure further detailed in [subrules a](#) and [b](#).

- a. The CO₂ Removal Supplier shall measure and declare the amount of electricity consumed in the capture process.
- b. Indirect emissions can be deemed mitigated or avoided and thereby set to zero in the quantification of CORCs, if one of the following conditions is demonstrated by the CO₂ Removal Supplier on an ongoing basis (i.e., at each Output Audit):

- (i) The production facility is connected to an electricity grid (as defined by the bidding zone or national boundaries) in which the average proportion of renewable electricity (excluding nuclear power) exceeded 90% in the previous calendar year or in which the emission intensity of electricity is lower than 18.0 gCO_{2e}/MJ (64.8 gCO_{2e}/kWh), as determined by national statistics.
- (ii) The production facility is connected to an electricity grid (as defined by the bidding zone or national boundaries) that is part of a cap-and-trade mechanism for emission reductions. The Issuing Body reserves the right to declare, prior to the audit, a specific cap and trade mechanism as insufficient in case it is deemed not stringent enough to ensure emission reduction (e.g. too many allowances). In addition, the supplier must procure renewable or low-carbon electricity from the grid via direct supply agreements or purchase of certificates following the requirements specified in [rule 5.2.13](#).
- (iii) The capture facility procures new renewable or low-carbon electricity (< 18.0 gCO_{2e}/MJ or 64.8 gCO_{2e}/kWh) from an electricity grid if all the following conditions are fulfilled for both supply and system-level measures.

Supply-level measures:

- Incrementality:⁵⁷ The procured electricity must be the result of new generation capacity and the installation generating renewable electricity must not have been in operation for more than 36 months before the carbon capture equipment is capturing carbon dioxide.
- The procurement is executed via long-term (i.e., at least 5 years) supply agreements or other similar instruments, from one or several electricity suppliers.
- The procured electricity must also follow the requirements specified in rule 5.3.6., in terms of spatial and temporal matching and information disclosure.

System-level measures:

⁵⁷ Aligned with the United States Inflation Reduction Act (Section 45V) and the EU's Renewable Energy Directive.

- The grid from which electricity is sourced must be on a trajectory towards full decarbonization before 2050.
- The carbon intensity of the grid from which electricity is sourced is already declining at the time of establishment of the carbon capture equipment.

The validity of this mitigation option shall be revised at least every 5 years.

(iv) The capture facility is consuming electricity produced off-grid that used to be sold to specific end-users (i.e. not as part of a grid, but rather an off-grid direct supply), and the CO₂ Removal Supplier can demonstrate that the previous end-users of the electricity have deployed or are planning to deploy other low-carbon means of meeting their energy demand (e.g. via energy efficiency measures, or deployment of new energy systems).

If none of the above conditions apply or can be demonstrated, then the indirect emissions from leakage remain unmitigated and must be quantified in accordance with the requirements in [section 6.4](#).

6.4 Quantification of non-mitigated indirect emissions

6.4.1 In cases where the assessment pursuant to [rule 6.3.3](#) results in unmitigated negative *ecological leakage, relating to effects on the nearby land and ecosystems surrounding the areas where facilities are built or extended*, the CO₂ Removal Supplier shall follow the procedure outlined in [subrules a](#) and [b](#) for the quantification and accounting of ecological leakage.

- The CO₂ Removal Supplier shall quantify the emissions related to the land disturbance in absolute terms, here denoted EL_x (in tCO₂e) for a given facility x (e.g., the electrochemical processing facility) within the Environmental Impact Assessment has as further detailed in [rule 6.3.3d](#).
- The absolute impact EL_x shall be added to the term E_{ECO} under $E_{indirect}$ (4.8) and amortized following the same procedure as for embodied emissions in [rules 5.2.15](#) and [5.2.16](#).

6.4.2 Non-mitigated leakage relating to electricity or consumption during the electrochemical processing stage shall be quantified as follows:

$$E_{MA} = Q_{MA} \times EF_{MA} \quad (6.1)$$

- The term E_{MA} is defined as a non-negative number ($E_{MA} \geq 0$), and hence cannot be negative.

- b. The term EF_{MA} is a positive number determined as the average emission factor of the grid (as defined by the bidding zone or national boundaries) to which the facility is connected.
- c. The CO₂ Removal Supplier shall annually update the value of the term EF_{MA} .

Variable	Description	Unit
E_{MA}	Market and activity leakage for the monitoring period.	tCO ₂ e
Q_{MA}	The amount of electricity consumed during the monitoring period for which leakage was not mitigated.	kWh
EF_{MA}	Emission factor for electricity.	tCO ₂ e/kWh

7 Monitoring and reporting

7.1 Overview

The main objectives for monitoring the direct air capture and ocean storage activity are:

Confirm the storage of CO₂.

Alert to increased risk of adverse events (e.g. CO₂ leaks, environmental contamination).

Verify that the electrochemical process reacts as expected to remove CO₂.

Identify any occurring adverse events.

Enable reliable quantification of stored carbon and any emissions.

Optimize DACOS operations.

While the resolutions or accuracies of individual tools in the monitoring suite may vary, it is the cumulative data from the monitoring approach as a whole that yields the necessary level of detail to determine with a very high degree of certainty that the CO₂ is effectively removed; that discharge sites, and the environment are being protected; and that any irregularities can be detected and addressed before they escalate.

It is important to note that robust monitoring can be achieved through several routes, and multiple monitoring techniques can often be utilized for the same parameter. For example, due to technological capabilities, there are two primary methods for quantifying the CO₂ removed as dissolved inorganic carbon (DIC) by the DACOS activity (see also [rule 4.3.3](#)):

1. direct measurement of changes in the DIC stream, and
2. modeled changes in DIC based upon several proxy variables including temperature, pH, and precipitation of solids.

In practice, the monitoring, reporting and verification procedure followed in this methodology consists of monitoring and reporting by the CO₂ Removal Supplier, verification by a recognized third-party auditor, and finally issuance of CO₂ Removal Certificates (CORCs). A key step in verifying the monitoring data consists of inspection of relevant evidence and corroborating calculations by the auditor. Depending on the requirement, the pieces of evidence themselves can take various forms, such as data records, permits, official documents, or other relevant information which demonstrate compliance with the requirements, and enable claims to be verified. If the auditor concludes, based on the evidence presented, that the carbon removal activity is compliant with the requirements of this methodology, the validated amount of CORCs is then issued to the CO₂ Removal Supplier.

7.2 General monitoring requirements

- 7.2.1 The CO₂ Removal Supplier shall prepare and make available to the Auditor documentation that demonstrates conformity of the DACOS activity with the requirements of this methodology, as well as the Puro Standard General Rules and other Standard Requirements.
- 7.2.2 The CO₂ Removal Supplier shall adopt a suite of monitoring technologies enabling the total amount of CO₂ Removal to be verified at the levels of resolution and certainty required by this methodology, and any applicable local regulations.
- 7.2.1 The CO₂ Removal Supplier shall ensure that the procedures for sample collection and handling are consistent with industry best practices.⁵⁸
- 7.2.2 Unless otherwise specified, all monitoring shall be based on data specific to the CO₂ Removal activity (i.e. the specific DACOS project which the CO₂ Removal Supplier seeks to certify under this methodology).
- 7.2.3 The CO₂ Removal Supplier shall ensure the accuracy of measurement devices as further detailed in [subrules a-d](#).
- a. All measurement devices shall be installed, operated and calibrated according to the device manufacturer's specifications or according to an appropriate industry consensus standard.
 - b. All measurement devices utilized for quantification shall be calibrated to an accuracy of at least 5% (i.e. the calibration error of any measurement device shall not exceed 5%) unless otherwise specified in this methodology or the project-specific QA/QC procedures.
 - c. Where applicable, the CO₂ Removal Supplier shall utilize certified reference materials (CRM) to establish the accuracy of the sensors used for the measurements.
 - d. Calibration records shall be made available for third-party verification.
- 7.2.4 The terminology used in this methodology in relation to the monitoring frequency shall be interpreted as detailed in [subrules a](#) and [b](#):
- a. The following definitions apply to the description of monitoring frequency:
 - (i) **Continuous** monitoring is defined as at least once every 15 minutes.
 - (ii) **Hourly** monitoring is defined as at least once every 60 minutes.
 - (iii) **Daily** monitoring is defined as at least once every 24 hours.

⁵⁸ For example, see the Guide to Best Practices for Ocean CO₂ Measurements (Dickson et al., 2007).

- (iv) **Monthly** monitoring is defined as at least once per calendar month.
 - (v) **Quarterly** monitoring is defined as at least four times per calendar year (once every three months).
 - (vi) **Semi-annual** monitoring is defined as at least twice per calendar year (once every six months).
 - (vii) **Annual** monitoring is defined as at least once per calendar year.
 - (viii) **Periodical** monitoring is defined as monitoring at predetermined, regular temporal intervals decided by the CO₂ Removal Supplier based on site-specific needs as well as any applicable regulations. The monitoring frequency and rationale thereof shall be explained in the Monitoring Plan.
- b. Monitoring activities with a predefined cadence (e.g. quarterly monitoring) shall be evenly distributed throughout the monitoring period (e.g. once every three months for quarterly monitoring). The CO₂ Removal Supplier may make reasonable adjustments to the monitoring schedule for reasons of necessity or practicality, but such adjustment shall not result in any undue or disproportionate delays to the monitoring activities.

7.2.5 The CO₂ Removal Supplier shall prepare, maintain, and comply with a Monitoring Plan for the DACOS activity. The Monitoring Plan shall contain the information detailed in [subrules a–k](#).

- a. **Monitoring team:** Definition of the roles and responsibilities of the monitoring team, including identifying the key personnel involved in data acquisition, monitoring, and reporting, along with their corresponding job titles. The CO₂ Removal Supplier shall furthermore outline the capacity and expertise of the monitoring team, including training practices and associated training materials.
- b. **Eligibility requirements:** Description of the how the DACOS activity meets the eligibility requirements (see [section 3](#)), and the procedures in place to monitor the fulfilment of the eligibility requirements (e.g. monitoring environmental and social impacts in support of SDGs (see [section 3.9](#)), and safeguarding against identified environmental and social risks (see [sections 3.8](#) and [7.5](#))).
- c. **Carbon sequestration:** Description of the procedures to monitor the carbon sequestration and GHG emissions of the DACOS activity, including a detailed description of the procedure to quantify the carbon removal with discreet, direct inline measurements of dissolved CO₂ and amount of carbonate mineral solids.

- d. **Energy consumption:** Demonstrated emissions impact including demonstrating that project consumption of electricity does not incrementally increase the load on the local electricity grid (see [section 6](#)).
- e. **Permanence:** Description of the procedures in place to verify the permanence of the sequestered CO₂ and ensure the reporting of any carbon losses or reversal events (see [sections 4.6](#) and [7.8](#)).
- f. **Contingency monitoring:** Description of how the CO₂ Removal Supplier plans to respond to any significant irregularities in the performance of the monitoring systems utilized in any stage of the system boundary (see [Figure 5.1](#)).
- g. **Equations:** List of the equation(s) used to calculate flows in mass or volume units of measurement and equations from which any non-measured parameters are obtained.
- h. **Equipment:** Descriptions of measurement devices, equipment, or instruments used to report data (if relevant) and how acceptable accuracy is demonstrated (e.g. installation, maintenance, and calibration method and frequency; see also [rule 7.2.3](#)). This includes, where applicable:
 - (i) **Instrument data:** Original equipment manufacturer (OEM) documentation or other documentation that identifies instrument accuracy and required maintenance and calibration requirements for all measurement devices used to collect necessary data for reporting.
 - (ii) **Calibration data:** The dates of measurement device calibration or inspection and the dates of the next required calibration or inspection. This data should further include laboratory practices for analytical calibration methodology, internal laboratory QC and audit procedures, and external laboratory verification of analytical accuracy.
- i. **Data collection, management, and storage:** Description of the procedures ensuring robust data collection, management, and archiving, including at least the following:
 - (i) **Data collection:** A data collection plan, including the type of data to be collected, associated details, and data collection techniques. The plan shall specify the frequency of monitoring and sample designs for directly sampled parameters.
 - (ii) **Data control:** Details on how data are controlled for the project, such as data storage, access controls, and data security measures. It is recommended to include a diagram illustrating the flow of data, indicating the responsible parties at each stage (see also [section 7.6](#)).

- (iii) **Data archiving:** Data and file archiving procedures, including procedures for any anticipated updates to electronic files. All data collected as a part of the monitoring process, including QA/QC data, shall be archived electronically and kept for at least 10 years after the end of the last project Crediting Period.
- j. **Quality control:** Description of the quality assurance and quality control (QA/QC) procedures in place to ensure accuracy of data collection, correction or removal of anomalous values, frequency of third-party independent checks on analysis results, and other similar quality control procedures as appropriate.
- k. **Change log:** A record of any changes to the document and processes, including any discrepancies or non-conformities detected during the audit.

7.3 Process boundaries for monitoring

Temporal boundaries

The monitoring timeline for DACOS projects can be expected to begin following site selection and continue throughout the operational period of the facility until decommissioning and the associated decommissioning monitoring. A schematic timeline of the various stages of project monitoring activities is depicted in [Figure 7.1](#).

- 7.3.1 The CO₂ Removal Supplier shall adhere to the requirements detailed in [subrules a–d](#) related to the timing of monitoring activities throughout the project lifetime (see also [Figure 7.1](#) for a visual representation of the timing of monitoring activities).
- a. **Baseline monitoring:** The CO₂ Removal Supplier shall establish ecological baseline monitoring (see [rule 7.5.2](#)) at least *six months* prior to discharge of seawater from the processing facility as part of the DACOS activity. The ecological baseline monitoring shall encompass monitoring of the facility site as well as of the intake and discharge water.
 - b. **Seawater processing and data collection:** The CO₂ Removal Supplier shall begin processing seawater and collecting the data required in this methodology at least *six months* prior to the start of the carbon removal activity (i.e. the start date of the first Crediting Period).
 - c. **Operational monitoring:** The CO₂ Removal Supplier shall begin monthly monitoring reporting (see [rule 7.6.3a](#)) within *one month* following the start of the carbon removal activity.

- d. **Decommission monitoring:** The CO₂ Removal Supplier shall continue decommission monitoring for at least *six months* following the decommissioning of the seawater processing facility.⁵⁹ The decommission monitoring shall encompass an area within a 5 km radius of the seawater discharge point.

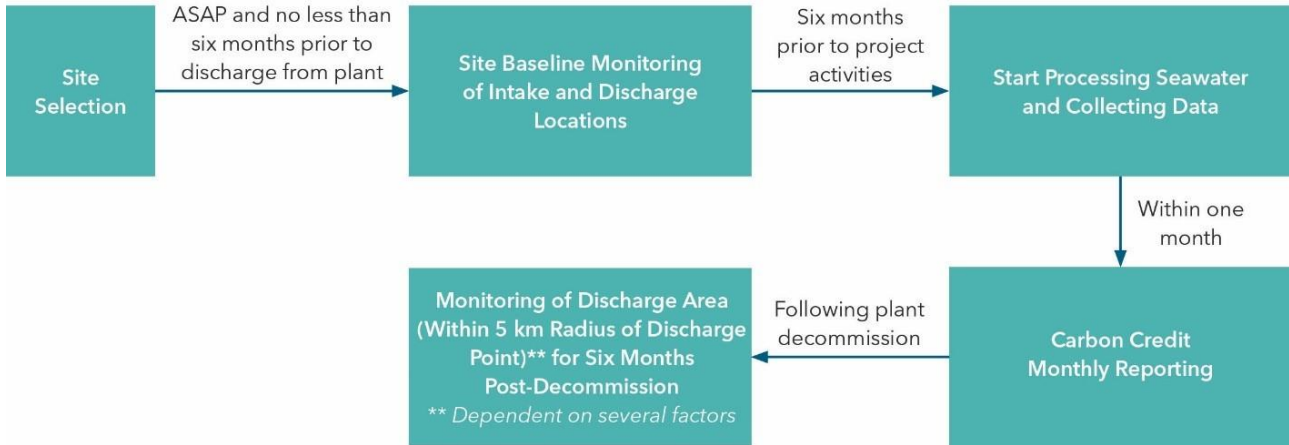

Figure 7.1 Monitoring timeline for a DACOS project

Spatial boundaries

7.3.2 The project spatial boundary for monitoring shall encompass at least the footprint of the plant site and includes the intake and outfall locations within a defined radius of the intake and outfall locations, as further defined in subrules a-c

- a. The spatial extent on monitoring around intake and outfall locations (monitoring radius) shall be determined by the CO₂ Removal Supplier based on the environmental impact assessment (see also rule 3.8.6).
- b. Further monitoring of locations outside of the immediate intake and outfall areas might occasionally be required e.g. for purposes of monitoring any potential environmental impacts, or changes in the carbonate chemistry, as informed by a review of the potential environmental impacts, hydrodynamic models, or other operational or background data.

7.3.3 The CO₂ Removal Supplier shall describe the spatial boundaries of monitoring utilizing an overview map of the plant and the locations of the intake, outfall, and potential discharge plume. The overview map shall furthermore identify nearby industrial processes and their associated discharges, as well as their proximity to the intake and discharge of the project included in the overview map.

⁵⁹ Further monitoring activities (e.g. sampling of discrete locations outside the project boundaries) may nevertheless be required for e.g. environmental monitoring purposes. This is further described in the project’s environmental monitoring and sampling plan.

7.3.4 The CO₂ Removal Supplier shall describe the minimum monitoring requirements relevant for the precise determination of the spatial and temporal monitoring boundaries in the environmental monitoring and sampling plan (see also [rule 7.5.1](#)).

7.4 Monitoring Parameters and Descriptions

In this methodology, CO₂ can be sequestered in two forms: solid mineral carbonates, and dissolved inorganic carbon (DIC) species comprising mainly of bicarbonate and carbonate ions. In order to determine the total amount of CO₂ removal resulting from the DACOS activity, it is necessary to measure several different physical and chemical parameters in various stages of the process (see [Figure 7.2](#)). The measured parameters include:

- temperature (T),
- salinity (S),
- pH,
- dissolved inorganic carbon (DIC),
- total alkalinity (TA),
- total suspended solids (TSS),
- magnesium concentration ([Mg]),
- calcium concentration ([Ca]),
- partial pressure of CO₂ in the aqueous phase (pCO₂(aq)) or gas phase (pCO₂(g)), and
- solids phase assemblage (Solids).

Note that temperature and salinity are necessary to calculate the full inorganic carbon speciation based on the measurement of a subset of parameters. Temperature further affects the chemical equilibria that describes carbon speciation, mineral dissolution, and mineral precipitation.

The process flow and monitoring locations are schematically depicted in [Figure 7.2](#). In essence, the chemical composition of the inlet seawater (point A) is compared with the outlet water (point E) with respect to the concentrations of calcium (Ca), magnesium (Mg), and dissolved inorganic carbon (DIC) species.⁶⁰ The total amount of CO₂ sequestered is determined from measurements at points A, B, D, and E.

⁶⁰ For DIC, the process can entail either a direct DIC measurement or a combination of measurements of pH, temperature, salinity, total alkalinity, pCO₂, and calculation of carbonate system speciation.

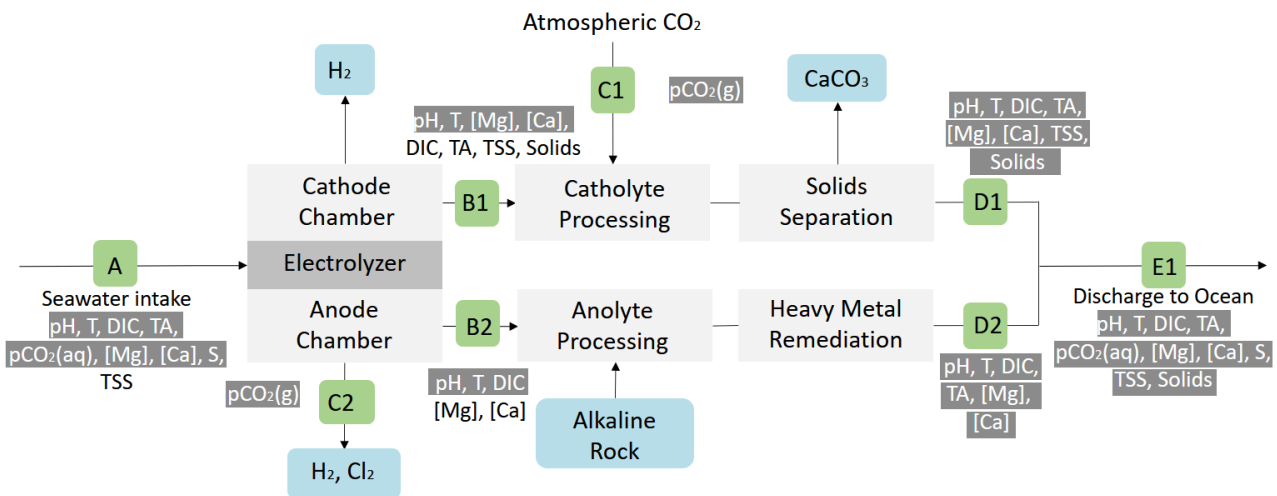

Figure 7.2 Simplified process flow diagram showing measurement locations (A through E), and the required and optional parameters for MRV. The required parameters are highlighted in grey.

7.4.1 The CO₂ Removal Supplier shall conduct a geochemical assay detailing the composition of the alkaline rock as further specified in [subrules a](#) and [b](#).

- a. The geochemical assay shall encompass at least the following properties:
 - (i) particle size distribution,
 - (ii) chemical oxide composition,
 - (iii) mineralogy, and
 - (iv) major and minor chemical elements.
- b. The geochemical assay shall be conducted at least once per every 5000 t of rock utilized, and whenever at least one of the following conditions is fulfilled:
 - (i) Rock is being utilized in a new Production Facility (i.e. beginning of project).
 - (ii) Rock is sourced from a new supplier or quarry.

7.4.2 The CO₂ Removal Supplier shall monitor the discharge water released to the ocean and ensure that its pH is at or above the pH of the intake seawater ($pH_{\text{discharge}} \geq pH_{\text{intake}}$).⁶¹

⁶¹ The increased alkalinity drives additional drawdown of CO₂ into the ocean over time. Note however that this additional post-discharge drawdown over time cannot be included in the quantification of CORCs, as this methodology does not provide a measurable way of crediting ocean alkalinity enhancement.

- 7.4.3 To prevent degassing of CO₂ from the processed seawater, the CO₂ Removal Supplier shall ensure that prior to the discharge of seawater from the electrochemical processing facility, a state of chemical equilibrium in the carbonate system⁶² has been attained in the discharge seawater, as further described in [subrules a](#) and [b](#).
- a. The CO₂ Removal Supplier shall compare the total concentration of dissolved inorganic carbon (DIC) species at point E in [Figure 7.2](#) (see also [rule 7.4.5](#) and the associated [Table 7.1](#)) to the equilibrium value corresponding to the observed seawater composition, pH, pCO₂, and seawater-to-catholyte mixing ratio. The CO₂ Removal Supplier shall compute this equilibrium point utilizing a suitable geochemical modelling software (e.g. PHREEQC, see (Parkhurst & Appelo, 2013)).
 - b. Any excess amount of DIC in the discharge seawater compared to its equilibrium value (obtained in accordance with [subrule a](#)) shall be treated as a loss of CO₂ and attributed to the term C_{loss} (see [rule 4.6.4b](#)).
- 7.4.4 The CO₂ Removal Supplier shall continuously monitor the rate of liquid and gas flows in the electrochemical processing system through direct measurements utilizing appropriate liquid and gas flow meters. The monitoring shall be performed in accordance with the general requirements of [rule 7.4.5a](#).
- 7.4.5 The CO₂ Removal Supplier shall monitor the chemical and physical parameters detailed in [Table 7.1](#) throughout the process flow, as further defined in [subrules a-c](#).
- a. All parameters shall be monitored utilizing a commercially available device. The monitoring shall be performed with a method in accordance with applicable local regulations or, if no such regulations exist, in accordance with an appropriate standard method published by a consensus-based standards organization, or industry standard practice. The CO₂ Removal Supplier shall detail the monitoring equipment and methods in the Monitoring Plan (see [rule 7.2.5](#)).
 - b. During the *startup phase* of the electrochemical processing facility (i.e. before reaching steady-state operations), the measurement frequency shall be:
 - (i) continuous for the parameters pH, T, S, pCO₂(aq), pCO₂(g), and TSS,
 - (ii) hourly for the parameters [Mg], [Ca], DIC, and TA, and
 - (iii) daily for the solids phase assemblage (Solids).
 - c. During the *steady-state operations phase* of the electrochemical processing facility, measuring frequency shall be:

⁶² The chemical reactions in the carbonate system govern the dissolution of CO₂ in the seawater and its subsequent sequestration (see [section 1.4](#), and in particular [equation \(1.5\)](#)).

- (i) continuous for the parameters pH, T, S, $p\text{CO}_2(\text{aq})$, $p\text{CO}_2(\text{g})$, and
- (ii) at least daily for [Mg], [Ca], DIC, and TA, TSS, and Solids.

Table 7.1 Required and optional measurements at the various sampling points.

Sampling Point	Sampling Location	Parameters sampled	Comments
Point A	At seawater intake	pH, T, DIC, TA, $p\text{CO}_2(\text{aq})$, salinity	Comment: All four carbonate system parameters will be measured to fully characterize the carbonate system.
Point B1	Catholyte immediately as it exits the cathode chamber	pH, T, [Mg], and [Ca]	Comment: The precipitation of CaCO_3 in the catholyte is limited by DIC in the feed water, reducing [Ca], whereas the precipitation of $\text{Mg}(\text{OH})_2$ depletes [Mg].
Point B2	Anolyte immediately as it exits the anode chamber	pH, T, and DIC (see note about DIC).	Comment: pH and DIC determine the extent of outgassing. Note: DIC is required only if $p\text{CO}_2(\text{g})$ is not measured at sampling point C2 Optional parameters: [Mg] and [Ca] if used for mass balance together with measurements in sampling point B1.
Point C1	CO_2 inlet/outlet during carbonation	$p\text{CO}_2(\text{g})$	Comment: The difference in molar amounts of CO_2 at the inlet and outlet, scaled with flow rate, is equivalent to the sum of CDR stored in solid CaCO_3 and the DIC difference between A and E (i.e. CDR from catholyte processing).
Point C2	CO_2 outlet at the anolyte holding tank	$p\text{CO}_2(\text{g})$	Comment: Outgassing at the anolyte will be detected at this point. Note: $p\text{CO}_2(\text{g})$ is required only if DIC is not measured at sampling point B2.
Point D1	Processed catholyte after carbonation	pH, T, DIC, TA, [Mg], [Ca], TSS, and solid phase assemblage.	Comment: This stream will have an elevated pH and DIC, depleted [Ca], and [Mg] which is roughly equivalent to that of the feed water. The carbonate system parameters pH, DIC, and TA will determine the extent of carbonation. From these parameters, $p\text{CO}_2(\text{aq})$ can be calculated to ensure complete carbonation to atmospheric equilibrium.

Sampling Point	Sampling Location	Parameters sampled	Comments
			The CaCO ₃ solids will be separated immediately after TSS measurements.
Point D2	Processed anolyte after re-alkalinization and heavy metal remediation	pH, T, TA, DIC, [Mg], and [Ca]	Comment: This stream will have an elevated pH, TA, and [Mg]. The concentration [Ca] is expected to be similar to that of the feed water. DIC may be variable, depending on the extent of ingassing.
Point E	Mixture of the processed anolyte and processed catholyte	pH, T, DIC, TA, pCO ₂ (aq), [Mg], [Ca], TSS, salinity and solid phase assemblage.	Comment: This stream will have high pH, DIC, TA, and [Mg], and reduced [Ca]. The simultaneous measurement of pH and DIC allows for the calculation of pCO ₂ , which will be compared with measured values. This constrains the CDR extent in the effluent and establishes the condition of “no outgassing” caused by nonlinear mixing with ambient seawater.

7.4.6 The CO₂ Removal Supplier shall determine the total carbon contained as solids species (CO_{2, solid}) through monitoring of the change in mass concentrations of calcium (Ca) and magnesium (Mg) in then electrochemical processing system as follows, and as further specified in [subrules a-d](#).⁶³

$$CO_{2, solid} = \sum_{j \in P} \frac{\Delta \rho_j}{M_j} \times F_{avg} \times SI \times R_{avg} \times M_{CO_2} \times 10^{-6} \frac{tCO_2}{gCO_2} \quad (7.1)$$

- a. The CO₂ Removal Supplier shall determine the change in the mass concentrations $\Delta \rho_j$ of alkaline-earth metal j (i.e. Ca or Mg) via direct measurement as follows.

$$\Delta \rho_j = \rho_j^A - \rho_j^D \quad (7.2)$$

- b. The CO₂ Removal Supplier shall determine the mole-fraction-weighted average ratio of moles of CO₂ removed per mol of solid carbonate minerals produced (R_{avg}) as follows based on the properties of the relevant minerals listed in [Table 4.1](#) and the mole fractions of the mineral phases formed, as determined via XRD and TGA analyses.

⁶³ Note that the values for CO_{2, solid} calculated in accordance with [rules 4.3.4](#) and [7.4.6](#) should yield the same results under the assumption that all carbonate solids are separated for weighing (see [rule 4.3.4a](#)). Note that in accordance with [subrule d](#), the value obtained from [rule 4.3.4](#) shall always be utilized for quantification of CORCs.

$$R_{avg} = \sum_{i \in S} x_i \times R_i \quad (7.3)$$

- c. The value for $CO_{2, solid}$ obtained from [equation \(7.1\)](#) shall be utilized solely for the purposes of process monitoring in accordance with [subrule d](#), and shall not be utilized for the quantification of CORCs (for which purpose, [rule 4.3.4](#) shall be applied).
- d. The CO₂ Removal Supplier shall compare the values for $CO_{2, solid}$ obtained through [equations \(4.5\)](#) and [\(7.1\)](#), and ensure that the values match to within 1% of whichever value is smaller in magnitude. In the case where a discrepancy larger than 1% arises, the CO₂ Removal Supplier shall determine and record the reason for the discrepancy, and take appropriate action to ensure that the performance of the electrochemical treatment process falls within the predetermined specifications (see also [rule 7.2.5f](#)).

Variable	Description	Unit
$CO_{2, solid}$	The total carbon contained as solids species as a product of the direct air capture and ocean storage activity	tCO ₂
$\Delta\rho_j$	The change in the mass concentration of alkaline-earth metal j (either Ca or Mg) between the seawater intake and solids separation (i.e. from Point A to Point D in Figure 7.2)	g/L
M_i	The molar mass of metal j .	g/mol
F_{avg}	The average liquid flow rate	L/min
SI	Sampling interval	min
R_{avg}	The mole-fraction-weighted average molar ratio of moles of CO ₂ removed per mol of solid carbonate minerals produced.	mol / mol
M_{CO_2}	The molar mass of CO ₂	g/mol
j	Summation index (an element of the set of alkaline-earth metals P)	unitless
P	The set of relevant alkaline-earth metals $P = \{Ca, Mg\}$	unitless
ρ_j^A	Mass concentration of metal j measured at point A in Figure 7.2	g/L
ρ_j^D	Mass concentration of metal j measured at point D in Figure 7.2	g/L
x_i	Mole fraction of the mineral i in the sample	%mol
R_i	The molar ratio of CO ₂ removed per mol of mineral i produced (see Table 4.1).	mol / mol
i	Summation index (an element in the set of mineral phases S)	unitless
S	Set of carbonate mineral phases. For the purposes of this methodology, the set of mineral phases consists of the minerals	unitless

	listed in Table 4.1 (aragonite, calcite, hydromagnesite, nesquehonite, and dypingite).	
--	--------------------------------------------------------------------------------------------------------	--

7.5 Monitoring of environmental and social impacts

7.5.1 The CO₂ Removal Supplier shall have in place, maintain, and comply with an environmental sampling and monitoring plan for the identified environmental and social risks associated with the DACOS activity (see [section 3.8](#)), as further detailed in [subrules a-d](#).

- a. The environmental sampling and monitoring plan shall include provisions for water quality, and other environmental monitoring at least to the extent required by local regulatory requirements, including but not limited to any requirements for local effluent discharge limits for waterways.⁶⁴
- b. The CO₂ Removal Supplier shall periodically monitor the environmental conditions of the project site within its spatial boundaries (see [section 7.3](#)) in accordance with the environmental sampling and monitoring plan.
- c. Any risk identified as a result of environmental monitoring shall be addressed or mitigated in accordance with the specific mitigation measures identified and detailed by the CO₂ Removal Supplier (see [rule 3.8.6b](#)).
- d. The CO₂ Removal Supplier shall disclose to the Issuing Body any negative impacts of the DACOS activity on the monitored environmental parameters or characteristics (e.g. the chemical water quality parameters in [rule 7.5.2a](#)). See also [rule 3.8.9](#).

7.5.2 The CO₂ Removal Supplier shall collect ecological baseline data in the planned DACOS activity deployment site, encompassing all parameters relevant to the determination of CDR, or the assessment of environmental impacts of the DACOS activity.

- a. The ecological baseline data shall include experimental measurements of chemical water quality characteristics of the seawater intake and discharge areas, including at least the following parameters:
 - (i) pH,
 - (ii) temperature,
 - (iii) salinity,

⁶⁴ For example, in the United States, relevant regulations include the criteria for surface water quality developed by the U.S. Environmental Protection Agency (USEPA) based on the Clean Water Act (33 U.S. Code § 1251 *et seq.*), such as the limits defined in the [National Recommended Water Quality Criteria - Aquatic Life Criteria Table | US EPA](#).

- (iv) pCO₂,
- (v) total alkalinity,
- (vi) dissolved inorganic carbon,
- (vii) dissolved magnesium, and
- (viii) dissolved calcium.

- b. The CO₂ Removal Supplier shall utilize the collected ecological baseline data as reference when assessing and monitoring the potential environmental impacts of the DACOS activity (see also [rule 3.8.6](#)), including in particular impacts to ocean ecology.

7.5.3 The CO₂ Removal Supplier shall collect and analyze grab samples of the seawater at the inlet and outlet of the electrochemical processing facility as further detailed in [subrules a-c](#).

- a. The CO₂ Removal Supplier shall collect samples at the inlet and outlet upon initial startup of the electrochemical processing facility, and periodically during steady-state operations. Effluent samples shall be collected before being discharged, and before mixing with any other discharge.
- b. The CO₂ Removal Supplier shall analyze the collected samples in accordance with industry best practices (e.g. according to the specifications of the latest edition of *Standard Methods for the Examination of Water and Wastewater* (APHA, 2023)).
- c. The CO₂ Removal Supplier shall adhere to all locally applicable laws and regulations relating to effluent limits and reporting procedures.⁶⁵

7.6 Data Management

7.6.1 The CO₂ Removal Supplier shall establish procedures for measuring or otherwise obtaining, recording, compiling, and analyzing data and information relevant to quantifying and reporting GHG emissions and removals of the project. Such procedures shall be in accordance with the ISO 14064-1 and 14064-2 standards.

7.6.2 The CO₂ Removal Supplier shall adhere to the principles of robust data acquisition, processing and accessibility described in [subrules a-c](#).

- a. The CO₂ Removal Supplier shall adhere to the following requirements regarding **data acquisition**:

⁶⁵ For example, in the United States, relevant regulations include the implementing regulations of the Clean Water Act under Title 40 of the Code of Federal Regulations ([40 CFR Part 122](#)).

- (i) The CO₂ Removal Supplier shall keep records of all data associated with DACOS activity to the extent required by this methodology as well as any applicable local laws, regulations, and other binding obligations.
 - (ii) The CO₂ Removal Supplier shall record all points of metering and sampling.
 - (iii) The CO₂ Removal Supplier shall collect the information listed in [Table 7.2](#) for all monitored parameters.
 - (iv) The CO₂ Removal Supplier shall maintain all meters and measuring devices according to OEM requirements to ensure accuracy and proper function (see also [rule 7.2.3](#)).
 - (v) The CO₂ Removal Supplier shall ensure that all personnel involved in sampling and data acquisition has received appropriate training, and has passed an initial demonstration of capability before any sampling or other activities related to data acquisition. All training records shall be stored and accessible electronically.
- b. The CO₂ Removal Supplier shall adhere to the following requirements regarding **data processing**:
- (i) The CO₂ Removal Supplier shall establish a procedure for the replacement of missing data. The CO₂ Removal Supplier shall obtain the substitute data points through a suitable scientifically robust model of the DACOS process (e.g. mass or energy balance). The supplier shall validate the results by using the remaining measured parameters and data at regular working conditions, considering a time period of the same duration as the data gap.
 - (ii) In cases where the CO₂ Removal Supplier utilizes the services of an external analytical laboratory, the CO₂ Removal Supplier shall obtain all data generated by the external laboratory.
 - (iii) The CO₂ Removal Supplier shall ensure that all process data, regardless of whether obtained from in-house measurements or from an external laboratory, is checked for accuracy, completeness, and consistency by an appropriately trained member of staff (e.g. the QA manager, MRV manager, or comparable) and incorporated into the project database.
 - (iv) Any data that is omitted shall be clearly labeled. A thorough explanation of the reason for the omission must be included.
- c. The CO₂ Removal Supplier shall adhere to the following requirements regarding **data availability**.

- (i) The CO₂ Removal Supplier shall ensure that the database records are directly and easily accessible to relevant staff members at the CO₂ Removal Supplier's service (e.g. through web-based software).
- (ii) The CO₂ Removal Supplier shall grant view-only access to relevant data records as necessary for purposes of external auditing, or similar due diligence procedures.

7.6.3 The CO₂ Removal Supplier shall have in place, maintain, and utilize an information system to keep records of all monitoring activities associated with the DACOS activity as further detailed in [subrules a-d](#).

- a. The records shall include information on the parameter or process monitored (i.e. what was monitored and how), as well as results of any measurements performed. In addition, the records shall include the following inputs and outputs on a monthly basis:
 - (i) Seawater input volume
 - (ii) Seawater output volume
 - (iii) Mass of rock delivered
 - (iv) Mass of rock utilized
 - (v) Weighted average rock emissions factor
 - (vi) Weighted average rock transportation distance
 - (vii) Electricity use from utility invoices
 - (viii) Natural gas use from utility invoices
 - (ix) Mass of co-products produced
 - (x) Mass of waste products produced
 - (xi) Weighted average waste transportation distance
 - (xii) GHG equivalent input
 - (xiii) GHG equivalent output
 - (xiv) GHG removal
- b. The information in these records shall be time-stamped and quantitative (where applicable).
- c. These records shall contain information for any omitted data. Any omitted data shall be clearly described including a thorough explanation of the reason for the omission.

- d. These records shall be available to the Auditor for the Production Facility Audit and Output Audits.
- e. These records shall be kept for at least two years after the end of the last Crediting Period, or the last issuance of CORCs for the project activity (whichever occurs later).

Table 7.2. Information to be compiled in the Monitoring Plan for each relevant parameter involved in the quantification of CORCs.

Variable	Description
ID	A unique identifier of the parameter.
Parameter name	The name of the parameter.
Description	A brief text describing what the parameter is about, and how it is used in calculations.
Value	The value of the parameter.
Unit	The unit of the parameter.
Uncertainty (%)	An estimation of the <i>random error</i> component associated with the obtained parameter value, and how the uncertainty was determined.
Equation	Reference to the equation(s) where this parameter contributes to (where applicable).
Source of data	A brief text describing where the data is sourced from: measured (m), calculated (c), or estimated (e).
Monitoring frequency	The frequency of monitoring of the parameter.
QA/QC procedures	A brief text describing how the data is obtained, via what measurements, and why the value selected is conservative in light of possible error or uncertainty.
Comments	Free text comments

7.7 Uncertainty assessment

Knowledge of uncertainty implies increased confidence in the validity of a measurement result (Ellison & Williams, 2012). For the purposes of this methodology, the main object of the uncertainty estimation is the quantification of the net carbon dioxide removal (see [equation \(4.1\)](#)), which in turn is affected by several parameters, measurements, and underlying assumptions, each with their own associated uncertainties. For example, some of the causes of uncertainty associated with carbon removal methodologies in general include:

- the assumptions made (e.g. the baseline scenario),
- the measurement model and its equations,
- the variables and their representativeness, and
- the measurement approaches used.

To be considered robust, the quantification of net carbon removal needs to be both *accurate* and *precise*, as both factors affect the *observational errors* (i.e. the difference between the measured value of a quantity and its true value) associated with the quantification. In general, observational errors can be separated into the two categories below.

- **Bias or systematic errors** may arise from conceptual errors or from an incomplete understanding of the processes included in the CORC quantification equation (measuring model) and its main components. This type of uncertainty impacts the *accuracy* of the net carbon removal estimation.
- **Random errors** may arise based on the inherent variability of the system, the representativeness of the data used to make the calculations, the measurement errors, and uncertainty obtained from expert judgement. This type of uncertainty impacts the *precision* of the net carbon removal estimation.

Extensive scientific literature exists on the causes, analysis, and management of uncertainties. For a practical guide, see e.g. the following sources:

- The IPCC Guidelines for National Greenhouse Gas Inventories, General Guidance and Reporting for information on the treatment of uncertainty (IPCC, 2006, 2019).
- EURACHEM/CITAC Guide CG 4: *Quantifying Uncertainty in Analytical Measurement* (Ellison & Williams, 2012).
- The of ISO/IEC Guide 98 suite of documents.⁶⁶

In general, the quantification accuracy and precision of a CO₂ removal method depend on the uncertainty associated with the processes, and the data inputs involved in quantification of GHG emissions and the resulting net carbon removal. For this methodology, the relevant causes of uncertainty are summarized in [Table 7.3](#). The reported uncertainty of the net carbon dioxide removal activity is the result of combining the standard uncertainties from the identified individual sources of uncertainty (see [rule 7.7.5c](#)), and expanding it to cover a confidence interval of approximately 95% (see [rule 7.8.3f](#)).

⁶⁶ The [ISO/IEC Guide 98 suite of documents](#) currently available:

ISO/IEC Guide 98-1:2024 Guide to the expression of uncertainty measurement — Part 1: Introduction;

ISO/IEC Guide 98-3:2008 Uncertainty of measurement — Part 3, Guide to the expression of uncertainty in measurement;

ISO/IEC Guide 98-4:2008 Uncertainty of measurement — Part 4, Role of measurement uncertainty in conformity assessment; and

ISO/IEC Guide 98-6:2021 Uncertainty of measurement — Part 6, Developing and using measurement models.

Table 7.3. Causes of uncertainty (IPCC, 2006, 2019)

Cause of uncertainty	Type	Mitigation
Lack of completeness	Bias	Concept, QA/QC
Model	Bias and random errors	Concept, QA/QC
Lack of data	Bias and random errors	Experts, QA/QC
Lack of representativeness of data	Bias	QA/QC, verification
Statistical random sampling errors	Random errors	Statistics sizes
Measurement error; random component	Bias and random errors	QA/QC, verification
Misreporting	Bias	QA/QC
Data gaps	Bias and random errors	Statistics, experts

7.7.1 The CO₂ Removal Supplier shall use conservative assumptions, values, and procedures to ensure that the CO₂ Removals issued as CORCs are not overstated.

7.7.2 The CO₂ Removal Supplier shall perform an uncertainty assessment of the implementation of the carbon removal activity in order to:

- a. identify the possible causes of uncertainty,
- b. establish actions to reduce that uncertainty through the design of the DACOS activity, and
- c. improve the accuracy and precision of the net carbon removal calculation.

7.7.3 The CO₂ Removal Supplier shall identify and report all material sources of uncertainty in the Output volume as further specified in [subrules a](#) and [b](#).

- a. For the purposes of this methodology, a material source of uncertainty is defined as any source of uncertainty, whose effect on the total Output volume during the monitoring period is, or can be reasonably assumed to be, 1% or greater (see also [rule 7.7.4](#)).
- b. The CO₂ Removal Supplier shall consider at least the following common sources of material uncertainty:
 - (i) Representativeness of the parameters utilized (e.g. the statistical dispersion in the value utilized for average liquid flow rates)
 - (ii) Measurement errors (e.g. the measurement/calibration error of the flow meter utilized for quantification of total dissolved inorganic carbon)

- (iii) Assumptions or estimations utilized by the CO₂ Removal Supplier (e.g. typical/estimated uncertainties of reference data sourced by the CO₂ Removal supplier, such as the physical properties, e.g. pressure or density of CO₂ at reference conditions).

7.7.4 For the purposes of this methodology, the procedure further defined in [subrules a](#) and [b](#) applies to uncertainties associated with the emission factors utilized for the determination of greenhouse gas emissions.

- a. Uncertainties associated with the emission factors utilized for the determination of greenhouse gas emissions are considered non-material (and therefore need not be considered), provided that *all of the following conditions* are fulfilled.
 - (i) The emission factors originate from LCA databases, local regulations, or other official sources (e.g. governmental, intergovernmental), and
 - (ii) The emission factors include upstream and downstream contributions as required in [section 5](#).
- b. For emission factors originating from sources other than those defined in [subrule a](#), a flat uncertainty of 20% of the value of the emission factor shall be assumed, unless an uncertainty has been determined by the publisher of the emission factor (in which case the determined value shall be used).

7.7.5 The CO₂ Removal Supplier shall quantify the uncertainties in the Output volume as detailed in [subrules a-c](#).

- a. The CO₂ Removal Supplier shall quantify each identified uncertainty (see [rule 7.7.3](#)) following the procedure in [subrule b](#).
- b. The CO₂ Removal Supplier shall directly quantify uncertainties (e.g. via calibration records, data provided in the product information of measuring devices, or statistical methods based on project data) where possible. Uncertainty estimations from external sources (such as peer-reviewed scientific literature or local regulations) or expert judgment may be utilized when necessary.
- c. The CO₂ Removal Supplier shall calculate the overall uncertainty (i.e. estimated standard deviation) in the Output volume utilizing a quantitative, scientifically justifiable method for the propagation of uncertainty such as the variance propagation formula, or Monte Carlo simulations.

7.7.6 The CO₂ Removal Supplier shall conduct the uncertainty assessment before the 1st Output Audit, and thereafter update it at least annually.

7.8 Performance reporting

- 7.8.1 The CO₂ Removal Supplier shall prepare and make available an Output Report to provide evidence of the Production Facility performance for the monitoring period.
- 7.8.2 The Output Report shall include supporting documented evidence for each monitoring period, in accordance with the scope and frequency of monitoring described in the Monitoring Plan (see [rule 7.2.5](#)), and with clause 6.13 (“Reporting the GHG project”) of the ISO 14064-2:2019 standard.⁶⁷
- 7.8.3 The Output Report shall include at least the information detailed in [subrules a-h](#):
- a. The name of the CO₂ Removal Supplier and operational partners.
 - b. The name and version number of the Puro Standard methodology being followed.
 - c. The date of the report and the time covered by it.
 - d. A brief description of the Production Facility, including its size, location, Crediting Period, and the type of carbon removal activity.
 - e. A CORC Summary with supporting detailed GHG calculations and evidence. The GHG emissions and removals shall be stated in units of tCO₂e. The CO₂ Removal Supplier may redact sensitive information (e.g. to comply with data providers end-user license agreements, or protect other sensitive commercial information) in accordance with the disclosure requirement of this methodology (see [rule 5.2.12b](#)) and of the Puro Standard.
 - f. A statement of uncertainty with the CORC Summary statement estimated with an approximate 95% confidence interval or two standard deviations of the mean, and how it has been addressed to minimise misrepresentation.
 - g. If applicable, details of any realized or suspected events which affect or can be reasonably thought to affect the permanence of the stored CO₂, including but not limited to reversal events, industrial accidents, and other unforeseen events.
 - h. If applicable, details of any changes to the Production Facility and Monitoring Plan. Any changes shall be clearly stated, and evidence of conformity with Puro Standard General Rules, the applicable Puro Standard methodology, and other Puro Standard requirements shall be provided for validation by the third-party Validation and Verification Body.

⁶⁷ ISO 14064-2:2019 Greenhouse gases, Part 2: Specification with guidance at the project level for quantification, monitoring and reporting of greenhouse gas emissions reductions or removal enhancements.

- 7.8.4 The Output Report shall be made available to the Auditor documentation for Audit to demonstrate conformity of the DACOS activity with the requirements of this methodology, the Puro Standard General Rules, and other Puro Standard requirements.
- 7.8.5 Any delays or changes in timescales or frequency of Output reporting shall be handled in accordance with the requirement of the Puro Standard General Rules.⁶⁸

⁶⁸ In the currently (Jan 2025) most recent version (Puro Standard General Rules v. 4.1), such requirements are listed in section 2.4 “Timescales and Frequency”.

8 Risk assessment and management

8.1 Overview

In the context of this methodology, *risk* refers to events and situations, whose outcomes are (reasonably well) known in advance, and distinguished from *uncertainty*, which refers to aspects of decision-making which are not easily quantified (Park & Shapira, 2017).⁶⁹

The overall risk of an event or situation is often defined as the combination of two parameters: the *probability* (likelihood) for the event to be realized, and the *severity* of the event, if realized. These parameters can, for example, be utilized to assess overall risk levels and define appropriate actions for different risk levels (see [Table 8.1](#)). Effectively, risk management is composed of four main steps: *identification*, *evaluation*, *mitigation* and *control* of hazards that could occur within the activity boundary. Therefore, an effective risk assessment takes into account the nature and magnitude of risks in relation to the outcome.

For the purposes of this methodology, the primary objective of identifying risks is to detect early and ongoing events and ambiguities that could affect the predetermined objectives of the DACOS activity. In general, the risks involved can be categorised into three main categories: **reversal** risks, **environmental** risks and **social** risks. While the scope and requirements of this methodology eliminate and limit most of the potential risks involved, it remains important for the CO₂ Removal Supplier to identify, account for, and mitigate any project-specific risk associated with the activity.

For the purposes of this methodology, the term **reversal** refers to an event which cancels, entirely or in part, the effects of an issued CORC (for further details, see the Puro Standard General Rules). Reversals are therefore considered as unaccounted for events resulting in a situation where at least a part of the removed, quantified and certified carbon represented as a CORC is either released back into the atmosphere (re-emission) or can no longer be considered safely and durably stored for a long term. It is separated from carbon losses (see [section 4.6](#)), which include re-emission pathways identified *prior* to the CORC issuance, and therefore accounted for in the CORC quantification (see [rule 4.3.1](#)).

An eligible DACOS activity must also take into consideration multiple **environmental and social risks**, which may negatively impact the terrestrial or marine ecosystems, human health or the local communities. This section—along with [sections 3.8](#) and [7.5](#)—outline the overall criteria to assess, evaluate and mitigate such risks, including certain predetermined risks which all projects seeking for CORC issuance must account for (see also [rule 3.8.6](#)). In addition to the requirements set in this methodology, further requirements and guidelines are also found in the Puro Stakeholder Engagement Report Template and the Puro Environmental and Social Safeguards Questionnaire.⁷⁰

⁶⁹ Note that besides the definition given here, the term *uncertainty* is also utilized in the context of statistical uncertainty, i.e. the (mathematically quantifiable) uncertainty associated with the use of sample data to make statements about the wider population. The statistical uncertainty in the context of this methodology is further addressed in [section 7.7](#).

⁷⁰ Available in the [Puro Standard document library](#).

This methodology, together with the applicable local legislation and regulations, sets the guidelines and rules to mitigate possible risks and ensure that the sequestered CO₂ is safely and durably stored as dissolved inorganic carbon the water, and as solid mineral carbonates. Appropriate and transparent collection of data as well as regularly updated monitoring plans are key factors in managing and mitigating risks, but effective risk mitigation also requires efficient and transparent communication and collaboration between the CO₂ Removal Supplier and the local authorities and stakeholders.

Table 8.1 An example of a 5x5 risk matrix with descriptions of the risk scores and corresponding actions for the given risk levels.

Risk score	Risk level	Action			
20–25	Inoperable	Critical failure. Requires an immediate seizure of operations. Further avoidance, minimization or mitigation measures are required for the operations to continue.			
10–19	Intolerable	High likelihood or severe negative impacts. Requires immediate action to avoid, minimize or mitigate the impacts.			
4–9	Undesirable	Manageable risks, which require an active, planned approach for risk avoidance, minimization and mitigation to reduce the negative impacts.			
2–3	Acceptable	Minor risks with limited negative impacts. No requirement of immediate action, but effective monitoring and controls are necessary.			
1	Negligible	Insignificant risk with negligible consequences. No requirement for immediate action but requires to avoid future events.			
Likelihood → Severity ↓	Very Low (1)	Low (2)	Medium (3)	High (4)	Very High (5)
Minor (1)	1	2	3	4	5
Serious (2)	2	4	6	8	10
Major (3)	3	6	9	12	15
Severe (4)	4	8	12	16	20
Extreme (5)	5	10	15	20	25

For all types of risk associated with the DACOS activity, identifying the key risks is the first step towards a design of an effective monitoring, mitigation and response measures to minimize their likelihood and impact. By proactively managing these risks, the CO₂ Removal Supplier ensures the integrity and safety of the operations.

Risks can be proactively managed by utilizing a mitigation hierarchy framework, which aims to efficiently limit the negative impacts or outcomes of a given risk. Such a hierarchy is based on a sequence of five iterative actions (Figure 8.1): anticipating the potential risk, avoiding the risk, minimizing and/or mitigating any negative impacts of the risk, and finally, compensating for any residual impacts. The steps are further characterised as:

- **Anticipation:** The first step comprises identifying potential risks relevant for a specific DACOS activity before they materialize, and designing strategies to either avoid, mitigate or minimize their impact.
- **Avoidance:** Includes measures taken to avoid any negative impacts identified for a given risk. For example, avoidance measures include the careful selection of the project site and alkaline rock feedstock. It is important to consider effective avoidance measures during the *early stages* of the project.
- **Minimization:** Includes measures to either reduce the duration, intensity or extent of a given risk, in case it cannot be fully avoided. Effective minimization measures may eliminate some negative impacts, if such measures are planned and executed accordingly.
- **Mitigation:** Includes measures to mitigate the impacts of a given risk, in case the impacts cannot be fully avoided or minimized. Collectively, avoidance, minimisation and mitigation measures serve to reduce, as much as possible, any negative residual impacts of a given risk.
- **Compensation:** As the last step, compensation measures are the last resort in case avoidance, minimisation and/or mitigation measures are not capable of fully preventing the negative impacts of a given risk. In the context of this methodology, this applies in the case of a reversal event.

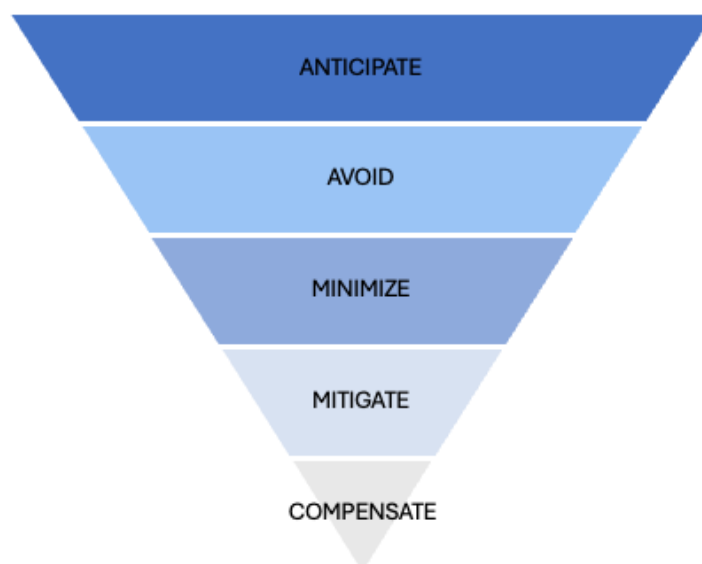

Figure 8.1. Mitigation hierarchy framework for risk assessment in the context of the DACOS approach.

8.2 Permanence and risk of reversal

Under natural conditions, the ocean absorbs and immobilizes atmospherically derived CO₂ in the form of dissolved carbonate species (predominantly HCO₃⁻ at a prevailing pH of approximately 8.1) (Doney et al., 2009; La Plante et al., 2023; NOAA, 2020). Such aqueous immobilization is highly durable on timescales of thousands of years (Caldeira & Akai, 2005; Renforth & Henderson, 2017). Furthermore, mineralization through the formation of calcite and aragonite (both polymorphs CaCO₃, i.e. minerals with the chemical formula CaCO₃, but with different crystal structures) results in very long-term storage of CO₂, in the order of millions of years (Sundquist, 1985; Veizer et al., 1989).⁷¹

In this methodology, the sequestered CO₂ is permanent and durably stored as dissolved ions comprising mainly bicarbonate (HCO₃⁻) and carbonate (CO₃²⁻), and as solid carbonates. The bulk of the solids produced via the DACOS process are separated from the processed seawater (see [rule 3.2.3](#)), and transported off site to be permanently stored or beneficially utilized (e.g. in construction materials, see [section 3.4](#)).

During catholyte processing, hydrated carbonate phases including nesquehonite (MgCO₃·3H₂O), lansfordite (MgCO₃·5H₂O), hydromagnesite (Mg₅(CO₃)₄(OH)₂·4H₂O), and dypingite (Mg₅(CO₃)₄(OH)₂·5H₂O) may form. These solids will tend to dissolve if they were to be discharged into the ocean because of the ocean's undersaturation concerning these phases. Furthermore, per unit of alkalinity, it is more chemically and energy efficient to immobilize CO₂ in the form of dissolved aqueous carbonates rather than mineral carbonate species.⁷² The dissolution of calcium

⁷¹ Note that although very stable under normal ambient circumstances, mineral carbonates can dissociate and release CO₂ if exposed to acid or extreme heat (usually several hundred degrees centigrade).

⁷² Note that the formation of 1 mole of CaCO₃ or MgCO₃ hydrates (e.g., nesquehonite: MgCO₃·3H₂O) captures 1 mole of CO₂, while requiring 2 moles of OH⁻. For comparison, only 1.2 moles of OH⁻ are required per mole of CO₂ stored as dissolved (bicarbonate: HCO₃⁻ and carbonate: CO₃²⁻) ions (La Plante et al., 2021; Renforth & Henderson, 2017).

carbonates and hydrated magnesium carbonates in the ocean increases the ocean's alkalinity and drives additional atmospheric CO₂ removal as dissolved HCO₃⁻ and CO₃²⁻ ions (Renforth & Henderson, 2017).

8.3 Requirements for risk assessment and management

Note that the Puro Standard General Rules contain requirements on risk assessment and management, particularly in the context of permanence and risk of reversal. Note further that requirements relating to an important aspect of risk management, i.e. the assessment and mitigation of environmental and social impacts, are also included in [sections 3.8](#) and [7.5](#).

8.3.1 The CO₂ Removal Supplier shall establish and maintain a comprehensive and project-specific risk assessment and mitigation process complying with the requirements of this Methodology, the Puro Standard General Rules and other Standard Requirements, as well as any applicable local laws, regulations, and other binding obligations.

8.3.2 The CO₂ Removal Supplier shall create, maintain, and periodically update a comprehensive risk assessment of the geological storage activity. The risk assessment shall encompass all stages of the activity boundary, and include a qualitative and/or quantitative analysis and evaluation of risks and their significance as described in [subrules a-c](#).

- a. The methods utilized for the analysis and evaluation of risks shall be scientifically justifiable and detailed in the risk assessment. For example, the CO₂ Removal Supplier may utilize risk assessment frameworks stemming from applicable local statutory requirements, relevant international standards (such as ISO 31000), scientific literature, or industry best practices.
- b. The risk assessment shall consider the risks and potential negative impacts to at least the following:
 - (i) The environment (including but not limited to soil quality, water contamination, ecosystems, habitats, and biodiversity).
 - (ii) The atmosphere.
 - (iii) Human health and safety.
 - (iv) Local communities and their socio-economic situation.
- c. The risk assessment shall contain at least the following components, encompassing the entire activity boundary:
 - (i) Risk identification, including characterization of each identified risk related to the DACOS activity; the conditions and context in which the individual risks might be realized; and the potential impacts of each identified risk.

- (ii) Risk analysis and estimation, including characterisation of the risk likelihood and severity, assessing the significance of the risk to the CO₂ Removal project.
- (iii) Risk evaluation, determining whether the risk likelihood and its severity are at an acceptable or tolerable level.
- (iv) Risk management measures, including a plan to mitigate and prevent the identified risks. Preventive and corrective measures shall be identified or planned as contingency measures to reduce risks and uncertainties.

- 8.3.3 As a part of the risk assessment, the CO₂ Removal Supplier shall assess whether there exist any such project-specific risk factors (such as those related to local environmental conditions, or the specific infrastructure utilized) that might lead to an elevated overall risk of reversal (in the sense described in [section 8.2](#)). In the case where, based on the assessment, the fraction of stored CO₂ retained is likely less than 99% over the first 1000 years, the CO₂ Removal Supplier shall undertake appropriate mitigation measures to reduce the overall risk of reversal to an acceptable level⁷³ or, if no such measures are feasible, apply a commensurate deduction to the reported Output volume.
- 8.3.4 The risk assessment shall, to the extent possible, be based on actual project data acquired during all stages of the geological storage activity. The risk assessment shall be periodically updated together with the Monitoring Plan. The CO₂ Removal Supplier shall set and periodically review appropriate preventive and corrective safeguards based on the risk assessment.
- 8.3.5 The CO₂ Removal Supplier shall record and disclose to the Issuing Body any risk realization events (including corrective measures taken and potential new safeguards or preventive measures set), as well as any resulting negative impacts or claims thereof, including but not limited to any legal actions and/or other written complaints filed by affected parties. The records shall be made available to the Auditor.
- 8.3.6 Due to the considerations on storage permanence and risk of reversal in [section 8.2](#), and given that this methodology imposes requirements to ensure that the DACOS activity is well managed as a whole, it is considered that in this methodology, there is no such material risk of reversal (in the sense defined in the Puro Standard General Rules) that would necessitate a default percentage deduction from the Output volume for all projects.

⁷³ An acceptable level of overall risk of reversal is defined as being likely that the fraction of stored CO₂ retained is more than 99% over the first 1000 years.

References

- APHA. (2023). *Standard Methods for the Examination of Water and Wastewater* (24th ed.). American Public Health Association, American Water Works Association, Water Environment Federation. <https://www.standardmethods.org/>
- Bond, F. C. (1961). Crushing and grinding calculations Part I. *British Chemical Engineering*, 6(6), 378–385.
- Caldeira, K., & Akai, M. (2005). Ocean storage. In B. De Yong & F. Joos (Eds.), *IPCC Special Report on Carbon Dioxide Capture and Storage* (pp. 278–318). https://www.ipcc.ch/site/assets/uploads/2018/03/srccs_wholereport-1.pdf
- Canadell, J. G., Monteiro, P. M. S., Costa, M. H., Cotrim da Cunha, L., Cox, P. M., Eliseev, A. V., Henson, S., Ishii, M., Jaccard, S., Koven, C., Lohila, A., Patra, P. K., Piao, S., Rogelj, J., Syampungani, S., Zaehle, S., & Zickfeld, K. (2021). Global Carbon and other Biogeochemical Cycles and Feedbacks. In V. Masson-Delmotte, P. Zhai, A. Pirani, S. L. Connors, C. Péan, S. Berger, N. Caud, Y. Chen, L. Goldfarb, M. I. Gomis, M. Huang, K. Leitzell, E. Lonnoy, J. B. R. Matthews, T. K. Maycock, T. Waterfield, O. Yelekçi, R. Yu, & B. Zhou (Eds.), *Climate Change 2021: The Physical Science Basis. Contribution of Working Group I to the Sixth Assessment Report of the Intergovernmental Panel on Climate Change* (pp. 673–816). Cambridge University Press. <https://doi.org/10.1017/9781009157896.007>
- Ciais, P., Sabine, C., Bala, G., Bopp, L., Brovkin, V., Canadell, J., Chhabra, A., Defries, R., Galloway, J., Heimann, M., Jones, C., Quéré, C., Myneni, R., Piao, S., & Thornton, P. (2013). Carbon and Other Biogeochemical Cycles. In T. F. Stocker, D. Qin, G.-K. Plattner, M. Tignor, S. K. Allen, J. Boschung, A. Nauels, Y. Xia, V. Bex, & P. M. Midgley (Eds.), *Climate Change 2013: The Physical Science Basis. Contribution of Working Group I to the Fifth Assessment Report of the Intergovernmental Panel on Climate Change* (pp. 465–570). Cambridge University Press. <https://doi.org/10.1017/CBO9781107415324.015>
- Cross, J. N., Sweeney, C., Jewett, E. B., Feely, R. A., McElhany, P., Carter, B., Stein, T., Kitch, G. D., & Gledhill, D. K. (2023). *Strategy for NOAA Carbon Dioxide Removal (CDR) Research: A White Paper documenting a potential NOAA CDR Science Strategy as an element of NOAA's Climate Intervention Portfolio* (Technical Report DOI: 10.25923/gzke-8730; NOAA Special Report). National Oceanic and Atmospheric Administration. <https://repository.library.noaa.gov/view/noaa/52072>
- Dickson, A. G., Sabine, C. L., Christian, J. R., Barger, C. P., & North Pacific Marine Science Organization (Eds.). (2007). *Guide to best practices for ocean CO₂ measurements*. North Pacific Marine Science Organization.
- DOE. (2023). *National Transmission Needs Study* [Technical report]. United States Department of Energy. https://www.energy.gov/sites/default/files/2023-12/National%20Transmission%20Needs%20Study%20-%20Final_2023.12.1.pdf
- Doney, S. C., Fabry, V. J., Feely, R. A., & Kleypas, J. A. (2009). Ocean Acidification: The Other CO₂ Problem. *Annual Review of Marine Science*, 1(Volume 1, 2009), 169–192. <https://doi.org/10.1146/annurev.marine.010908.163834>
- Ellison, S. L. R., & Williams, A. (Eds.). (2012). *EURACHEM/CITAC Guide: Quantifying Uncertainty in Analytical Measurement* (3rd ed.). EURACHEM/CITAC. https://eurachem.org/images/stories/Guides/pdf/QUAM2012_P1.pdf
- E.U. Copernicus Marine Service Information. (2023). *Global Ocean acidification—Mean sea water pH time series and trend from Multi-Observations Reprocessing*. <https://doi.org/10.48670/moi-00224>

- Friedlingstein, P., O'Sullivan, M., Jones, M. W., Andrew, R. M., Hauck, J., Olsen, A., Peters, G. P., Peters, W., Pongratz, J., Sitch, S., Le Quéré, C., Canadell, J. G., Ciais, P., Jackson, R. B., Alin, S., Aragão, L. E. O. C., Arneeth, A., Arora, V., Bates, N. R., ... Zaehle, S. (2020). Global Carbon Budget 2020. *Earth System Science Data*, 12(4), 3269–3340. <https://doi.org/10.5194/essd-12-3269-2020>
- Hartmann, J., West, A. J., Renforth, P., Köhler, P., De La Rocha, C. L., Wolf-Gladrow, D. A., Dürr, H. H., & Scheffran, J. (2013). Enhanced chemical weathering as a geoengineering strategy to reduce atmospheric carbon dioxide, supply nutrients, and mitigate ocean acidification. *Reviews of Geophysics*, 51(2), 113–149. <https://doi.org/10.1002/rog.20004>
- Harvey, C., Delacroix, S., & Tard, C. (2024). Unraveling the competition between the oxygen and chlorine evolution reactions in seawater electrolysis: Enhancing selectivity for green hydrogen production. *Electrochimica Acta*, 497, 144534. <https://doi.org/10.1016/j.electacta.2024.144534>
- He, J., & Tyka, M. D. (2023). Limits and CO₂ equilibration of near-coast alkalinity enhancement. *Biogeosciences*, 20(1), 27–43. <https://doi.org/10.5194/bg-20-27-2023>
- IEA. (2024). *Global Hydrogen Review 2024*. IEA.
- IPCC. (2006). *2006 IPCC Guidelines for National Greenhouse Gas Inventories*. IPCC National Greenhouse Gas Inventories Programme. <https://www.ipcc-nggip.iges.or.jp/public/2006gl/>
- IPCC. (2019). *2019 Refinement to the 2006 IPCC Guidelines for National Greenhouse Gas Inventories*. <https://www.ipcc-nggip.iges.or.jp/public/2019rf/index.html>
- Jones, D. C., Ito, T., Takano, Y., & Hsu, W.-C. (2014). Spatial and seasonal variability of the air-sea equilibration timescale of carbon dioxide. *Global Biogeochemical Cycles*, 28(11), 1163–1178. <https://doi.org/10.1002/2014GB004813>
- Karunadasa, K. S. P., Manoratne, C. H., Pitawala, H. M. T. G. A., & Rajapakse, R. M. G. (2019). Thermal decomposition of calcium carbonate (calcite polymorph) as examined by in-situ high-temperature X-ray powder diffraction. *Journal of Physics and Chemistry of Solids*, 134, 21–28. <https://doi.org/10.1016/j.jpcs.2019.05.023>
- La Plante, E. C., Chen, X., Bustillos, S., Bouissonnie, A., Traynor, T., Jassby, D., Corsini, L., Simonetti, D. A., & Sant, G. N. (2023). Electrolytic Seawater Mineralization and the Mass Balances That Demonstrate Carbon Dioxide Removal. *ACS ES&T Engineering*, 3(7), 955–968. <https://doi.org/10.1021/acsestengg.3c00004>
- La Plante, E. C., Simonetti, D. A., Wang, J., Al-Turki, A., Chen, X., Jassby, D., & Sant, G. N. (2021). Saline Water-Based Mineralization Pathway for Gigatonne-Scale CO₂ Management. *ACS Sustainable Chemistry & Engineering*, 9(3), 1073–1089. <https://doi.org/10.1021/acssuschemeng.0c08561>
- Lechat, K., Lemieux, J.-M., Molson, J., Beaudoin, G., & Hébert, R. (2016). Field evidence of CO₂ sequestration by mineral carbonation in ultramafic milling wastes, Thetford Mines, Canada. *International Journal of Greenhouse Gas Control*, 47, 110–121. <https://doi.org/10.1016/j.ijggc.2016.01.036>
- NOAA. (2020). *Ocean acidification*. National Oceanic and Atmospheric Administration. <https://www.noaa.gov/education/resource-collections/ocean-coasts/ocean-acidification>
- Park, K. F., & Shapira, Z. (2017). Risk and Uncertainty. In M. Augier & D. J. Teece (Eds.), *The Palgrave Encyclopedia of Strategic Management* (pp. 1–7). Palgrave Macmillan UK. https://doi.org/10.1057/978-1-349-94848-2_250-1
- Parkhurst, D. L., & Appelo, C. a. J. (2013). Description of input and examples for PHREEQC version 3: A computer program for speciation, batch-reaction, one-dimensional transport, and

- inverse geochemical calculations. In *Techniques and Methods* (6-A43). U.S. Geological Survey. <https://doi.org/10.3133/tm6A43>
- Pullin, H., Bray, A. W., Burke, I. T., Muir, D. D., Sapsford, D. J., Mayes, W. M., & Renforth, P. (2019). Atmospheric Carbon Capture Performance of Legacy Iron and Steel Waste. *Environmental Science & Technology*, 53(16), 9502–9511. <https://doi.org/10.1021/acs.est.9b01265>
- Renforth, P. (2019). The negative emission potential of alkaline materials. *Nature Communications*, 10(1), 1401. <https://doi.org/10.1038/s41467-019-09475-5>
- Renforth, P., & Henderson, G. (2017). Assessing ocean alkalinity for carbon sequestration. *Reviews of Geophysics*, 55(3), 636–674. <https://doi.org/10.1002/2016RG000533>
- Sabine, C. L., & Tanhua, T. (2010). Estimation of Anthropogenic CO₂ Inventories in the Ocean. *Annual Review of Marine Science*, 2(1), 175–198. <https://doi.org/10.1146/annurev-marine-120308-080947>
- Sand, M., Skeie, R. B., Sandstad, M., Krishnan, S., Myhre, G., Bryant, H., Derwent, R., Hauglustaine, D., Paulot, F., Prather, M., & Stevenson, D. (2023). A multi-model assessment of the Global Warming Potential of hydrogen. *Communications Earth & Environment*, 4(1), 1–12. <https://doi.org/10.1038/s43247-023-00857-8>
- Strefler, J., Amann, T., Bauer, N., Krieglner, E., & Hartmann, J. (2018). Potential and costs of carbon dioxide removal by enhanced weathering of rocks. *Environmental Research Letters*, 13(3). <https://doi.org/10.1088/1748-9326/aaa9c4>
- Sun, H., Gao, Z.-Y., Zhao, D.-R., Sun, X.-W., & Chen, L.-Q. (2021). Spatial variability of summertime aragonite saturation states and its influencing factor in the Bering Sea. *Advances in Climate Change Research*, 12(4), 508–516. <https://doi.org/10.1016/j.accre.2021.04.001>
- Sundquist, E. T. (1985). Geological Perspectives on Carbon Dioxide and the Carbon Cycle. In *The Carbon Cycle and Atmospheric CO₂: Natural Variations Archean to Present* (pp. 55–59). American Geophysical Union (AGU). <https://doi.org/10.1029/GM032p0005>
- Takahashi, T., Sutherland, S. C., Wanninkhof, R., Sweeney, C., Feely, R. A., Chipman, D. W., Hales, B., Friederich, G., Chavez, F., Sabine, C., Watson, A., Bakker, D. C. E., Schuster, U., Metzl, N., Yoshikawa-Inoue, H., Ishii, M., Midorikawa, T., Nojiri, Y., Körtzinger, A., ... de Baar, H. J. W. (2009). Climatological mean and decadal change in surface ocean pCO₂, and net sea–air CO₂ flux over the global oceans. *Deep Sea Research Part II: Topical Studies in Oceanography*, 56(8), 554–577. <https://doi.org/10.1016/j.dsr2.2008.12.009>
- Veizer, J., Hoefs, J., Lowe, D. R., & Thurston, P. C. (1989). Geochemistry of Precambrian carbonates: II. Archean greenstone belts and Archean sea water. *Geochimica et Cosmochimica Acta*, 53(4), 859–871. [https://doi.org/10.1016/0016-7037\(89\)90031-8](https://doi.org/10.1016/0016-7037(89)90031-8)
- Watson, A. J., Schuster, U., Shutler, J. D., Holding, T., Ashton, I. G. C., Landschützer, P., Woolf, D. K., & Goddijn-Murphy, L. (2020). Revised estimates of ocean-atmosphere CO₂ flux are consistent with ocean carbon inventory. *Nature Communications*, 11(1), 4422. <https://doi.org/10.1038/s41467-020-18203-3>
- Wilson, S. A., Harrison, A. L., Dipple, G. M., Power, I. M., Barker, S. L. L., Ulrich Mayer, K., Fallon, S. J., Raudsepp, M., & Southam, G. (2014). Offsetting of CO₂ emissions by air capture in mine tailings at the Mount Keith Nickel Mine, Western Australia: Rates, controls and prospects for carbon neutral mining. *International Journal of Greenhouse Gas Control*, 25, 121–140. <https://doi.org/10.1016/j.ijggc.2014.04.002>
- Wolf-Gladrow, D. A., Zeebe, R. E., Klaas, C., Körtzinger, A., & Dickson, A. G. (2007). Total alkalinity: The explicit conservative expression and its application to biogeochemical processes. *Marine Chemistry*, 106(1), 287–300. <https://doi.org/10.1016/j.marchem.2007.01.006>

Zeebe, R. E. (2012). History of Seawater Carbonate Chemistry, Atmospheric CO₂, and Ocean Acidification. *Annual Review of Earth and Planetary Sciences*, 40(1), 141–165. <https://doi.org/10.1146/annurev-earth-042711-105521>